



USERS MANUAL FOR MOBILE APPLICATIONS

# W-SC6 / SC10

- 3000 RPM -

Mobile diesel generating set 230V / 50Hz

Digital Diesel Control



Art.nr. 40261111

WHISPER POWER BV  
Kelvinlaan 82  
9207 JB Drachten  
The Netherlands  
Tel.: +31-512-571550  
Fax.: +31-512-571599  
[www.whisperpower.eu](http://www.whisperpower.eu)

V1 September 2008

## CONTENTS:

<b>1</b>	<b>INTRODUCTION</b> .....	<b>4</b>
1.1	General .....	4
1.2	Service and maintenance .....	4
1.3	Guarantee .....	4
1.4	Liability .....	5
1.5	Identification .....	5
1.5.1	General.....	5
1.5.2	Identification plate.....	6
<b>2</b>	<b>INFORMATION</b> .....	<b>7</b>
2.1	Safety .....	7
2.1.1	General.....	7
2.1.2	Electrical safety .....	7
2.1.3	Earth insulation failures .....	7
2.1.4	Installation .....	7
2.1.5	Operation.....	8
2.1.6	Fire and explosion .....	8
2.1.7	Chemicals.....	8
2.2	Transport, lifting and storage.....	9
2.3	W-SC6 / SC-10.....	9
2.3.1	Features .....	9
2.3.2	Remote control .....	9
2.3.3	Documentation .....	9
2.4	Components.....	10
2.4.1	Main components to identify .....	10
2.4.2	Generator control panel.....	12
2.4.3	Remote control panel .....	12
2.5	Technical Information .....	12
2.5.1	AC alternator .....	12
2.5.2	Engine .....	12
2.5.3	Digital Diesel Control system.....	12
2.5.4	Battery charger.....	12
2.5.5	Alarms and shut down .....	13
2.5.6	Control.....	13
2.5.7	Remote control .....	13
2.5.8	Hour counter.....	13
2.5.9	Load indicator .....	13
2.5.10	Fuel specification.....	13
2.5.11	Oil information .....	13
2.5.12	Cooling liquid.....	14
2.5.13	Technical data .....	14
2.5.14	Wiring codes and colours .....	15
2.5.15	Lay outs control wiring.....	16
2.5.16	Electrical diagrams 230 V AC / 50 Hz.....	19
2.5.17	Electrical diagrams radiator fan control .....	20
2.5.18	Diagram electronic governor (standard) .....	22

<b>3</b>	<b>OPERATION .....</b>	<b>23</b>
3.1	General .....	23
3.2	Operating Instructions .....	23
3.2.1	Summarised operating instructions (daily use) .....	23
3.2.2	Extended operating instructions .....	23
<b>4</b>	<b>MAINTENANCE .....</b>	<b>25</b>
4.1	Alternator .....	25
4.2	Engine .....	25
4.2.1	Preliminary instructions .....	25
4.2.2	Bleeding fuel lines .....	25
4.2.3	Valve clearance .....	25
4.2.4	Replacing fuel filter .....	25
4.2.5	Replacing oil filter .....	25
4.2.6	Readjustment V-belt/placing oil filter .....	26
4.2.7	Air strainer element .....	26
4.3	Regular maintenance .....	26
4.3.1	Maintenance schedule .....	27
4.3.2	Putting out of service .....	27
<b>5</b>	<b>TROUBLE SHOOTING .....</b>	<b>28</b>
5.1	Alternator/ electrical faults .....	28
5.1.1	General .....	28
5.1.2	Trouble shooting table alternator .....	28
5.2	Engine faults .....	29
5.2.1	General .....	29
5.2.2	Trouble shooting table engine .....	30
5.2.3	Warnings .....	32
5.2.4	Service address .....	32
5.3	Special procedures alternator .....	33
5.3.1	Residual voltage check / excitation procedure .....	33
5.3.2	Testing rotary rectifier diodes .....	33
5.3.3	Winding resistant values .....	33
5.3.4	Meggering .....	33
5.4	Special procedures engine .....	34
5.4.1	Setting the RPM .....	34
5.4.2	Adjusting valve clearance and retightening the cylinder head bolts .....	34
5.4.3	Disassembling instructions .....	35
<b>6</b>	<b>SPARE PARTS LIST .....</b>	<b>36</b>
	<b>MAINTENANCE LOG .....</b>	<b>38</b>

# 1 INTRODUCTION

## 1.1 GENERAL

The W-SC6 / SC10 -3000RPM mobile diesel generating set is manufactured and marketed by Whisper Power.

It is important to read this manual before installing and operating the generating set. Both safety and durability rely very much on the correct identification, installation and a good understanding of ratings, features, design, maintenance and operation procedures.

The information, specifications, illustrations and statements contained within this publication are given with our best intentions and are believed to be correct at the time of going to press.

All of the specifications, provisions and instructions contained in this manual apply solely to standard versions of the W-SC6 / SC10 -3000RPM mobile diesel generating set, first launched in September 2008

This manual is valid for the following models:

Part number	Description
41102020	W-SC6, 230V 3000rpm Mobile / keel cooling
41102026	W-SC6, 230V 3000rpm Mobile / keel cooling -ungrounded
41104020	W-SC10, 230V 3000rpm Mobile / keel cooling
41104026	W-SC10, 230V 3000rpm Mobile / keel cooling -ungrounded

For other models see other manuals available on our website: [www.whisperpower.eu](http://www.whisperpower.eu)

Our policy is one of continued development and we reserve the right to amend any technical information without prior notice.

Whilst every effort is made to ensure the accuracy of the particulars contained within this publication neither the manufacturer, distributor, or dealer in any circumstances shall be held liable for any inaccuracy or the consequences thereof.



### WARNING

A warning symbol draws attention to special warnings, instructions or procedures which, if not strictly observed, may result in damage or destruction of equipment, severe personal injury or loss of life.



### DANGER

This danger symbol refers to electric danger and draws attention to special warnings, instructions or procedures which, if not strictly observed, may result in electrical shock which will result in severe personal injury or loss of life.



### DANGER

Realise that people are not used to have 230V available on a vehicle. Put warning signs on wall sockets and on junction boxes. Instruct non-regular users of the vehicle. Warn maintenance personal of garages that do service on the vehicle.

## 1.2 SERVICE AND MAINTENANCE

Regular service and maintenance should be carried out according to the directions in this manual. For service and maintenance one can appeal to the manufacturer or the dealers.

## 1.3 GUARANTEE

Whisper Power guarantees that this generating set has been built according to good workmanship, according to the specifications in this manual and according to European Community safety regulations.

During production and prior to delivery, all of our generating sets are tested and inspected.

The well functioning of this generating set is subject to guarantee. The period and conditions of this guarantee are laid down in the general conditions of delivery as registered with the Chamber of Commerce and Industries for the North of the Netherlands number 01120025 and are available on request. The guarantee period is two years, limited to 1000 running hours. Some aspects of our guarantee scheme are given here in more detail:

Guarantee does not cover failures that are caused by misuse, neglect or a faulty installation.

**Example 1. Faulty installation:**

Overheating of the engine or alternator is the most common cause of problems with mobile generating sets. These problems are caused by poor circulation of the cooling liquid due to wrong routing of the pipes to the radiator: bents will capture air bubbles causing "air-locks" blocking the circulation of the liquid. Other examples of installation problems are hot air circulation into the radiator and the radiator fan sucking exhaust gasses into the radiators.

The generator and other parts should be protected against the influences of the weather and splashing water (with dirt and salt) below the vehicle. Refer to the installation manual for instructions but remember these are for guidance only as many factors influence the installation of a generator. The ultimate responsibility will always be with the owner to ensure a safe and compliant installation. If in doubt ask!

**Example 2: Misuse:**

Long term running with no load or too little load can cause the exhaust to get choked with soot or carbon. Cleaning the exhaust is not covered by guarantee.

**Example 3: Neglect**

Whisper generators have an option for an auto start/stop mode or interval mode.

Whisper Power cannot be held responsible for damage caused by the unattended running generator.

Guarantee means that faulty parts are repaired or replaced free of charge. If necessary the whole generator unit will be exchanged. Labour necessary to complete repairs on board a vehicle executed by an authorized service engineer is covered, but is limited to a reasonable number of hours and reasonable rates in relation to the actual repair work that has to be done.

Travel expenses and travel hours are not covered. Also not covered is the labour required to take a generator out of a vehicle or for reinstallation. There is no cover for labour needed to get access to the generator, for example to remove equipment or parts of the vehicle body etc.

Goods to be delivered under guarantee will be invoiced. Only after the faulty goods are returned will the invoice be credited. Payment in advance may be required or guaranteed by credit card. If after the faulty goods are returned, it is indicated that the failure was not covered by guarantee a credit will not be issued. For example if a Printed Circuit Board is returned with clear damage caused by water, guarantee will be refused.

Freight costs to deliver spares by normal mail or carriers is covered under guarantee. Special services like express mail, overnight delivery etc. are not covered. Taxes and

duties are not covered. For shipments to remote areas any additional costs incurred over normal carriage will be invoiced to the customer.

The cost for returning faulty goods is not covered under guarantee.

If any problem arises which could be subject of guarantee, procedures should be followed as described in the guarantee conditions, unauthorised repairs could lead to further damage and violate the guarantee conditions.



Should work take place, which is not in accordance with the guidelines, instructions and specifications contained in this user's manual and the supplementary installation manual, then damage may occur and the generating set may not fulfil its specifications. In all these cases the guarantee may become invalid. Use original spareparts only!

## 1.4 LIABILITY

Whisper Power does not accept responsibility for damage, injuries or casualties which are the result of operation of the generating set in specific conditions which brings dangers which could not be foreseen, or could be avoided by additional measures. Whisper Power does not accept liability for damage due to use of the generator, possible errors in the manuals and the results thereof.

### **Automatic start/stop**

**Whisper Power cannot be held responsible for damage caused by the unattended running generator using the auto-start/stop mode or interval mode.**

## 1.5 IDENTIFICATION

### 1.5.1 General

Before using this generating set it is very important to identify the set correctly. To communicate for service or ordering parts it is also essential to correctly identify the generating set. Also for the daily operation of the generating set it is necessary that the operator knows the correct specifications.

### 1.5.2 Identification plate

All required identification data are on the identification plate. For location of the identification plate see figure 1

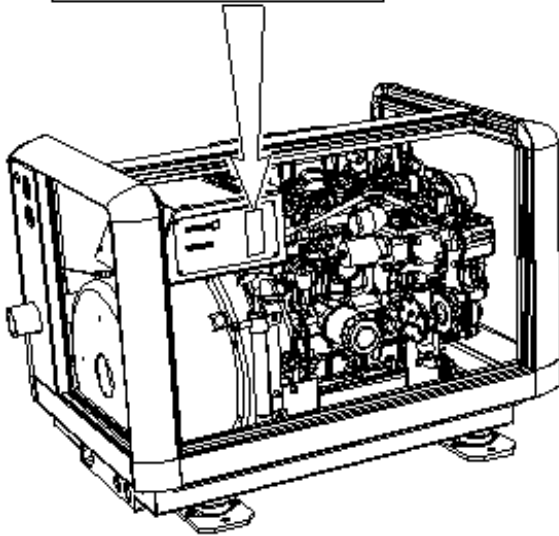
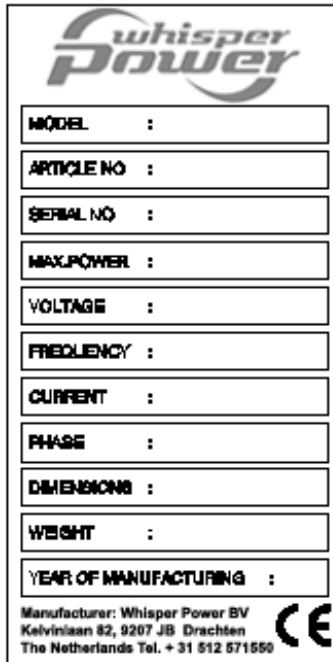

Fig. 1: Location identification plate.

- 1 The identity of the generating set is given by the SERIAL NUMBER.  
When this number is available the manufacturer can trace the specifications of the generating set. On the identification plate are also some basic features of the set:

### 2 POWER

The identification plate gives the nominal maximum continuous load in kVA (= kW) calculated with power factor one. When calculating a load one should always take into account the power factor or cos phi of this load. The power should never exceed the nominal power as shown on the identification plate. Power is rated at an ambient temperature of 25°C. For higher temperatures the generating set has to be derated. To drive the radiator fan (230 V fan) output could be taken from power generated by the genset.

In that case net power will be less than specified on the identification plate.

- 3 VOLTAGE shows the nominal voltage.  
This voltage should be within the specified tolerance at the nominal frequency.
- 4 FREQUENCY is shown in Hz and is determined by the speed of the engine (RPM). 50 Hz correlates with 3000 rpm.
- 5 CURRENT shows the maximum current that is acceptable at the specified frequency, voltage and power factor.
- 6 WEIGHT shows the net dry weight (approximately) in kg. This is without fuel, oil, cooling liquid, packing and external installation equipment
- 7 CE-marking: the "CE" symbol shows that the generating set is build according to European Community safety regulations. This includes the regulations regarding the safety of pleasure craft, safety of machinery, electric safety and electric magnetic compatibility (EMC) and other relevant directives.

Safety also relies on the installation, application and circumstances. See also the remarks in this manual under SAFETY

Before changing a factory setting you are advised to consult the manufacturer. When the generating set you have to identify is not new you have to take into account the possibility that former users may have changed the settings. Check the settings (voltage, frequency, rpm) when there is any doubt.

## 2 INFORMATION

### 2.1 SAFETY

#### 2.1.1 General

When correctly installed and used in normal circumstances this generating set fulfils EC safety regulations. This generating set could be part of an installation or could be used in a way that additional regulations of the EC or other authorities have to be taken into account.



Circumstances could make it also necessary to take additional measures. Be aware of wet conditions and hazardous environments caused by explosive gases etc

#### 2.1.2 Electrical safety



The voltage of 230 Volt generated by this generating set is dangerous and if instructions and procedures are not strictly observed may result in electrical shock which will result in severe personal injury or loss of life.



Realise that people are not used to have 230V available on a vehicle. Put warning signs on wall sockets and on junction boxes. Instruct non-regular users of the vehicle. Warn maintenance personal of garages that do service on the vehicle.

- Check all wiring at least once a year. Defects, such as loose connections, burned cables etc. must be repaired immediately.
- Do not work on the electrical system if it is still connected to a current source. Only allow changes in your electrical system to be carried out by qualified electricians.
- Connection and protection must be done in accordance with local standards.
- **Using the auto-start/stop (interval) mode the generator can start unexpectedly. When working on the electrical system, the 3 Amp fuse must be removed from the control panel and the battery plus cable must be removed from the battery.**



Warning signs indicate parts which could be live.

#### 2.1.3 Earth insulation failures

According to local regulations and depending on the application it could be necessary to take measures for protection against earth insulation failures.

In the standard delivery “neutral” and “ground” are not connected. To make a connection between “neutral” and “ground” could be necessary as part of a specific insulation failure protection system.



In all situations the transfer switches between shore, inverter and generator should switch both neutral and L1. Of course this is the case when using a Mastervolt Mass Systemswitch.

#### 2.1.4 Installation

Whisper generating sets are not self contained and have to be properly installed in enclosed areas. Installation includes measures to be taken to outlet exhaust fumes which contain carbon monoxide and are extremely dangerous. Carbon monoxide (CO) is an invisible odourless gas. Inhalation produces headache, nausea or death. Installation includes measures for proper ventilation, safe electric connections, safe installation of the starting battery, proper fitting of the cooling system and fuel pipes etc. Refer to the installation manual.



Do not use the generator set when the vehicle is inside a building or in other enclosed area's. Be aware using the generator in wind still conditions, when the exhaust fumes could accumulate under, around or even in the vehicle.

### 2.1.5 Operation

External moving parts like fans and V-belts are covered by the soundshield and therefore the W-SC6 / SC10 is very safe when the soundshield is closed.



Nevertheless take note of the signs on the generating set which show symbols in a triangle indicating danger.



When service has to be carried out while the engine is running, be aware of moving parts like V-belts.

- The generating set should be operated by authorised personnel only.
- Be aware of hot parts and especially parts of the exhaust system and the cooling system.
- If the generating set is unsafe, fit danger notices and disconnect the battery positive (+) lead so that it cannot be started until the condition is corrected.
- Do not attempt to operate the generating set with a known unsafe condition. Disconnect the battery positive (+) lead prior to attempting any repairs or cleaning inside the enclosure.
- Always consult the manual before carrying out maintenance.
- Do not change the settings without consulting the manufacturer. Keep a record of setting changes in this manual.

### 2.1.6 Fire and explosion



Fuels can be flammable. Proper handling limits the risk of fire and explosion.

- Avoid refilling the fuel tank while the engine is running. When oil or fuel is leaking do not use the generating set.
- Do not run the engine close to explosives or gasses.
- Hydrogen gas generated by charging batteries is explosive. Ensure for proper ventilation. Do not smoke or allow sparks, flames, or other sources of ignition around batteries.
- Keep a fire extinguisher on hand.



Fig. 2: Fire extinguisher port.

- In case of fire do not open the soundshield. To avoid serious injury or death from fire, shut down engines, generator sets and blowers. Break through the label which is indicated by BREAK THROUGH HERE and then immediately discharge entire contents of gaseous portable fire extinguisher through the fire extinguisher port. On the generating set this fire extinguisher port is indicated by the label as shown in figure 2.
- Poor electrical connections or using wiring which is not suited for the rated currents can cause overheating and possibly fire.

### 2.1.7 Chemicals

- Fuels, oils, coolants, and battery electrolyte can be hazardous to personnel if not treated properly. Do not swallow or have skin contact with these liquids. Do not wear clothing that has been contaminated by fuel or lubricating oil.
- Gaskets may be manufactured from asbestos. Particles of this material should not be inhaled as this may result in fatal diseases.
- On no account allow any unprotected skin to come into contact with the injector spray as the fuel may enter the blood stream with fatal results.
- Engines may be fitted with seals or O-rings manufactured from "viton" or similar material. When exposed to abnormal high temperatures in excess of 400°C an extremely corrosive acid is produced which cannot be removed from the



skin. If signs of decomposition are evident, or if in doubt, always wear disposable heavy duty gloves.

## 2.2 TRANSPORT, LIFTING AND STORAGE



When lifting the generating set avoid any risk of personal injuries, do not stand under the generating set.

- Use soft slings to avoid damage
- On the engine are two hoist eyes which can be used to take the generator out of the capsule. They can also be used to lift the complete generating set including the capsule.
- After transporting the generating set check for damage before installation.
- Long term storage can have detrimental effects on engine and alternator. The engine should be put through an engine preservation procedure. (Refer to the maintenance chapter)
- The alternator windings tend to condense. To minimise condensation, store the generating set in a dry and warm storage area.
- After removing the generating set from long term storage perform an insulation check. (Refer to the alternator maintenance paragraph for procedures)
- While the battery is stored it should be recharged every 12 weeks.

## 2.3 THE W-SC6 / SC10

### 2.3.1 Features

This generating set includes a diesel engine which is connected by close coupling to an alternator in a sound attenuated capsule. The set is mounted on a steel base frame and mounted securely on anti vibration mounting pads to the capsule base. All cables and hoses are guided through the capsule's sides. The set is not self contained and is only operable after proper installation using additional accessories and installation materials.

Installation accessories are listed in the installation manual and are available through the supplier of the generating set. The full automatic Digital Control is based on microprocessor technology. Several automatic start/stop functions can be programmed and monitored (refer to Digital Diesel Control users manual).

### 2.3.2 Remote control

The full automatic remote control panel including 15 mtr cable comes as standard with the Whisper generating set.

### 2.3.3 Documentation

Included in the delivery are:

- This users manual (number: 40261111)
- An installation manual (number: 40261121)
- A users manual for DCC (number: 50200261).
- A quick reference guide for DDC (number 50200275)

Not included in the standard delivery but available as options are:

- Parts manual (Whisper 6): number 40200181
- Parts manual (Whisper 10) number 40200182
- Workshop manual; number: 40200171

However in this manual there is a list of important parts for maintenance and spare parts as well as a chapter on maintenance and problem solving.

## 2.4 COMPONENTS

### 2.4.1 Main components to identify

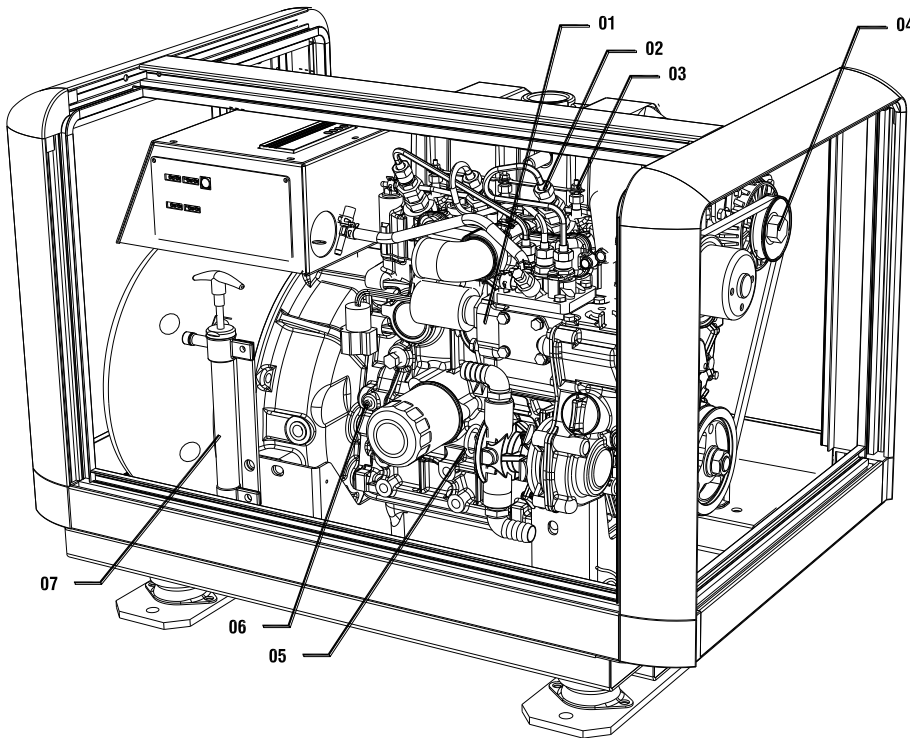

- 01 Fuel injection pump
- 02 Fuel injector
  - W-SC6: 2x
  - W-SC10: 3x
- 03 Glow plug
  - W-SC6: 2x
  - W-SC10: 3x
- 04 Alternator (12VDC)
- 05 Engine oil dipstick
- 06 Coolant drain plug
- 07 Oil sump hand pump

Fig. 3 Front View main components W-SC 6 and SC10

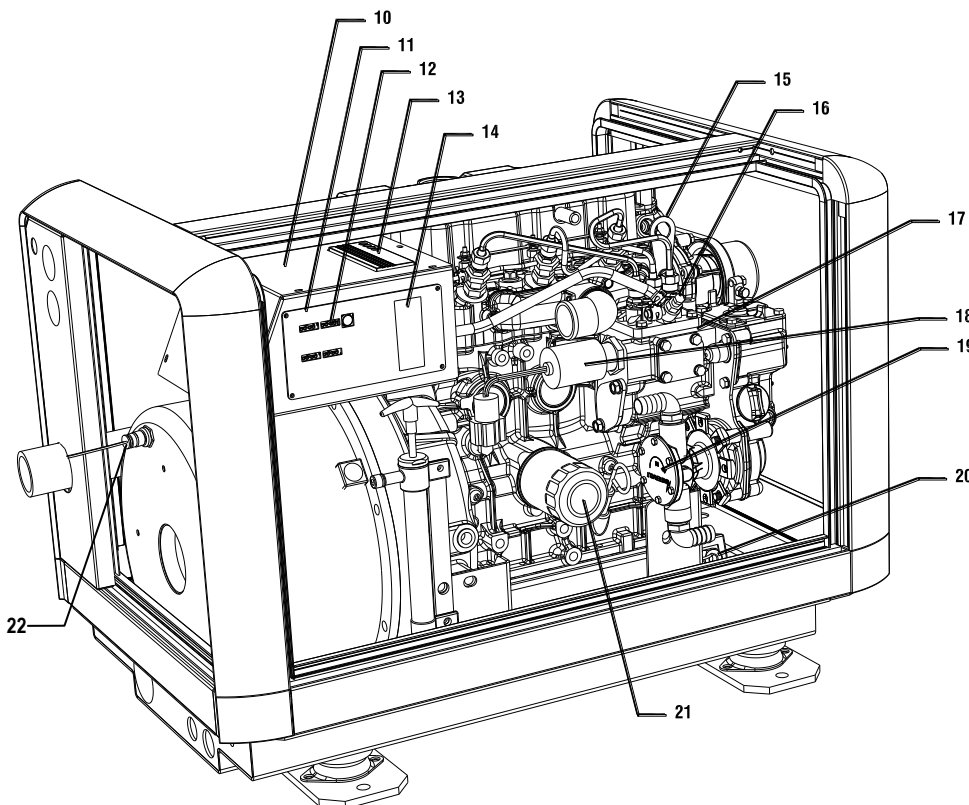

- 10 Air cleaner element
- 11 Control panel
- 12 Fuses
- 13 Digital Diesel Control (DDC)
- 14 Identification plate
- 15 Hoist eye front
- 16 Injection pump air bleeding screw
- 17 Engine speed adjustment screw
- 18 Fuel solenoid
- 19 Water pump of the alternator cooling circuit
- 20 Fuel lift pump
- 21 Engine oil filter
- 22 Alternator temperature switch

Fig. 4: Front view main components W-SC 6 and SC10

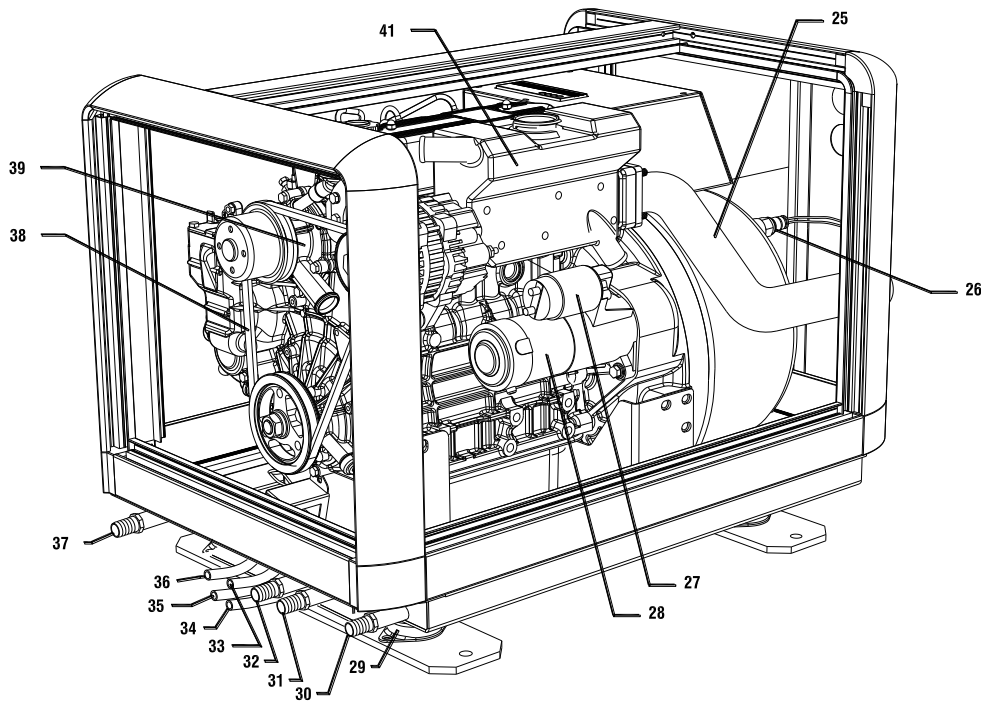

- 25 Dry exhaust
- 26 Temperature switch alternator
- 27 Starter motor solenoid
- 28 Starter motor
- 29 Rubber engine mounting
- 30 Coolant generator out
- 31 Coolant engine in
- 32 Coolant engine out
- 33 Battery negative (-)
- 34 Fuel in Ø8mm
- 35 Fuel out Ø8mm
- 36 Battery positive (+)
- 37 Coolant generator in
- 38 V-belt
- 39 Engine coolant pump

Fig. 5: Rear view main components W-SC 6 and SC10

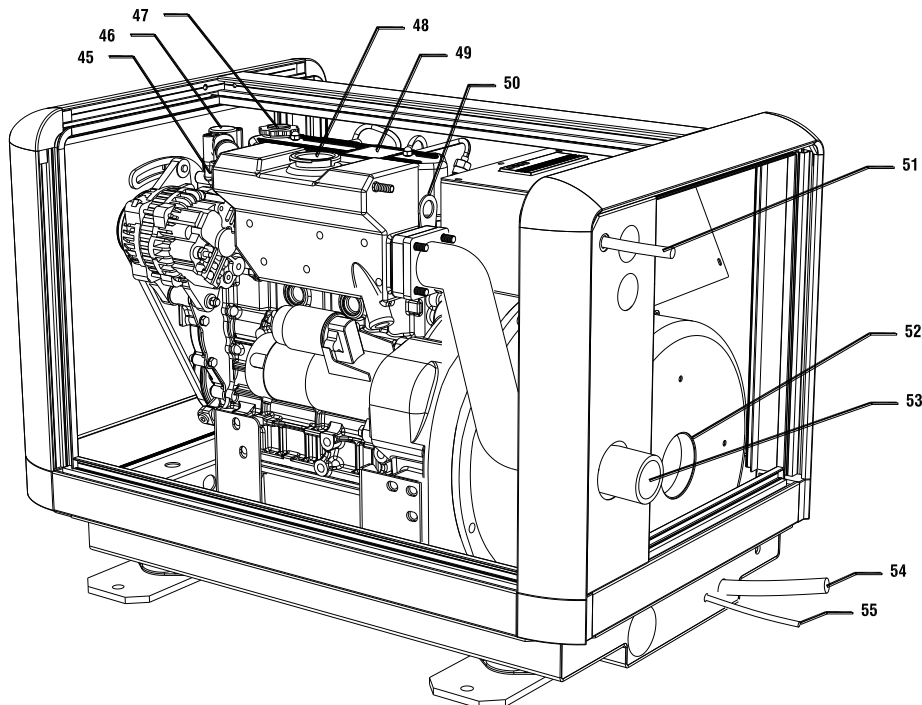

- 45 Temperature switch
- 46 Thermostat housing
- 47 Filler cap engine oil
- 48 Filler cap engine coolant
- 49 Rocker cover
- 50 Hoist eye rear
- 51 Expansion tank
- 52 AC Generator
- 53 Exhaust 1½"
- 54 AC power output
- 55 Remote control

Fig. 6: Rear View main components W-SC 6 and SC10

## 2.4.2 Generator control panel

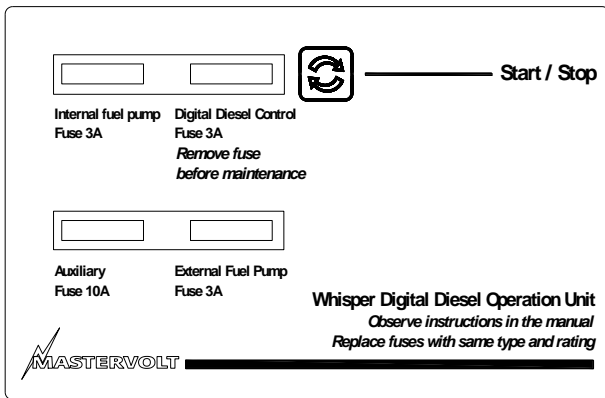

Fig: 7 Control panel.

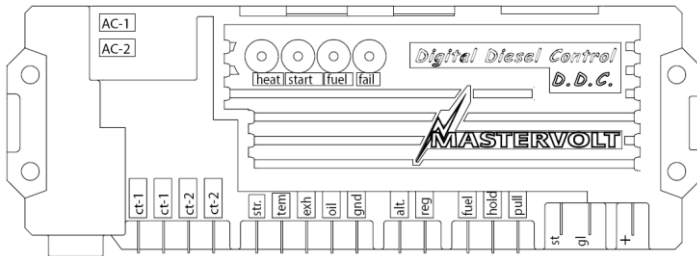
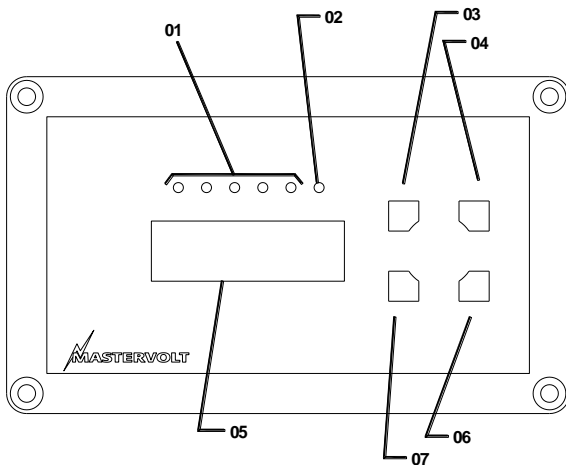

Fig. 8 Digital Diesel Control unit

## 2.4.3 Remote control panel



- 01 Generator load indicator
- 02 Failure LED
- 03 Start button
- 04 Stop button
- 05 Display
- 06 Select button
- 07 Set button

Fig. 9: Digital Diesel remote control panel

## 2.5 TECHNICAL INFORMATION

### 2.5.1 AC alternator

The single phase synchronous alternator is directly coupled, one bearing, brushless, rotating field design, two poles (3000 RPM) and self regulating

Residual magnetism causes a small voltage over the stator windings and allows a current to flow in the windings, which is magnified because of the feed back effect between rotor and stator. The field windings in the rotor are short-circuited over a diode to rectify the current. A capacitor over an additional winding in the stator which is at an angle with the power-winding keeps the voltage stable within 5 % at the specified rpm and provides voltage fall off with speed, preventing over-excitation at low engine speeds and softening the effect of load switching to relieve the burden on the engine.

The alternator is water cooled and the cooling liquid is cooled by a radiator. Further technical data on the design of the alternator can be found in drawings and diagrams in this manual.

### 2.5.2 Engine

The W-SC6 generating set is based on the Mitsubishi L2E 2 cylinder diesel engine; the W-SC10 generating set is based on the Mitsubishi L3E 3 cylinder diesel engine. The engine is indirectly injected. The engine is water cooled and the cooling liquid is cooled by a radiator.

The engine has been specially adapted for the Whisper Power application and is very different from the standard engine supplied for industrial applications!

### 2.5.3 Digital Diesel Control system

The standard electrical engine control system is 12 Volt negative earth, non earth return (ungrounded) is available as option. Check your identification data to determine which system is applied. The system is designed according to the "energise to run" system. The Digital Diesel Control is a very advanced microprocessor based full automatic system. Besides automatic start the system offers many monitoring options. Refer to the separate Digital Diesel Control users manual.

The microprocessor unit is located in the black box on top of the alternator

### 2.5.4 Battery charger

On the engine is an alternator generating 40 Amp 12V. This current is rectified to charge the battery. The voltage is regulated at  $\pm 14.4V$ .

### 2.5.5 Alarms and shut down

In the event of malfunctioning this will be indicated by the failure light, details will be shown on the display and the engine will be shut down. There are three functions guarded: oil pressure, coolant temperature and alternator temperature.

Too high alternator temperature indicates the alternator coolant to be blocked or the pump impeller to be damaged.

All alarm switches are closed when no malfunction occurs. A contact is cut in the event of an alarm. This means that the generating set will not work when the alarm switches are broken or there is a loose wire. The system therefore is intrinsically safe. The panel will display details about the alarm.

### 2.5.6 Control

The generating set can be operated by push buttons on the panel on the alternator or by the remote control. By pushing the START button the control system is activated and will start the engine automatically. Pushing the STOP button will stop the engine and the electrical system will be deactivated.

### 2.5.7 Remote control

All wiring connections from the remote control to the board are made by plug in connectors.

An intermediate communication cable is in the standard supply. If necessary an optional longer 8 wire communication cable can be connected if the standard length does not suit the required distance. Numerous remote control units can be put in parallel by using the connectors on the back of the units. (Refer to installation instructions)

### 2.5.8 Hour counter

The remote control offers several timer functions that helps to schedule maintenance.

### 2.5.9 Load indicator

On the remote control the load will be indicated on the display and by the LED-bar. The load is measured by a current transformer on the alternator.

### 2.5.10 Fuel specification

The engine must only be used with diesel fuel oil which conforms to the standards for use in modern diesel engines. Fuel free from water and contaminants is of the utmost importance.

### 2.5.11 Oil information

1 Specification:

The oil must be suitable for oil changes as specified in the maintenance chapter. The Mitsubishi engine must be run on heavy duty lubricating oil meeting the requirements of API class CD, CF or CF\_4.



It is very important to use the correct oil specification. Very often local oil suppliers recommend a higher class, because they assume that a higher class is allowed. This is not the case. One should not follow these recommendations.

Using the wrong specification will cause high oil consumption.

2 Oil viscosity:

We recommend a multigrade oil 15W40.

3 Oil capacity:

The content of the crankcase is as specified below:

	W-SC6	W-SC10
Excluding oil filter:	2,4 l	3,6 l
Including oil filter:	2,9 l	4,1 l

Do not overfill with lubricating oil as this may have a detrimental effect on engine performance

4 Oil pressure

- Minimum at idle 49 Kpa (0,5 kgf/cm<sup>2</sup> - 7psi).
- Normal at 3000 rpm between 147 and 490 Kpa (1,5 up to 5 kgf/cm<sup>2</sup> - 21 up to 71 psi).
- Minimum at 3000 rpm 98 Kpa (1,0 kgf/cm<sup>2</sup> - 14 psi).

### 2.5.12 Cooling liquid

Both the engine and alternator are cooled by cooling liquid. The capacity of both systems depend on the size of the radiator piping and other parts in the cooling system

We recommend not using water but cooling liquid that is marketed for the use in combustion engines. Cooling liquid protects the engine against frost to minus 25° C. Also it protects the engine block against corrosion. Initially one can fill the engine via the filling cap on the exhaust manifold. Fill up till the level is just below the filling cap. Filling of the alternator cooling system and additional filling of engine cooling system has to be done via the expansion tanks. When the engine is on temperature the liquid will expand and the redundant liquid will be pressed into the

expansion tank. This tank has to be filled up till the mark. On the tank is an overflow connection. This connection can be used to connect an open hose to drain the overflow of the cooling liquid to outside the vehicle.

When cooling liquid is not available clean fresh water could be used with an additive of anti freeze. When using water with anti freeze the right mixture has to be calculated according to the information of the supplier of the anti freeze.

The cooling liquid in the engine is pressurised. A high pressure hose connects the manifold to the expansion tank. The cooling liquid in the alternator is not pressurised. The alternator's expansion tank has an open connection to drain liquid and release air

### 2.5.13 Technical data

#### GENERAL

Model	W-SC6	W-SC10
RPM	3000	3000
Alternator	water cooled, synchronous	water cooled, synchronous
Engine	Mitsubishi diesel, model L2E	Mitsubishi diesel, model L3E
Number of cylinders	2	3
Displacement	635 cm3	952 cm3
Bore X stroke	76x70 mm	76x70 mm
Combustion air consumption	0.95 m3/min.	1.43 m3/min.
Continuous power engine	5 kW	10 kW
Cooling system	By means of a radiator.	By means of a radiator.
Fuel lift pump engine	electric pump (12 V DC), additional pump available upon request	
Starting battery (optional)	60-90 Ah 12V	60-90 Ah 12V
Fuel consumption	1-2.5 litre/hour, load dependent	1-4 litre/hour, load dependent
Control	Digital Diesel Control including automatic start/stop	

#### GENERAL

Model	W-SC6	W-SC10
Output voltage	230V 50 Hz alternating current (AC) single phase	
Output rating	5kW at powerfactor cos phi = 1	9kW at powerfactor cos phi = 1
Voltage tolerance	± 5%	± 5%
Frequency tolerance	± 1% (electronic governor)	± 1% (electronic governor)
Alternator	Brushless, four pole, synchronous	Brushless, four pole, synchronous
Voltage regulation:	Capacitor	Capacitor

#### MECHANICAL SPECIFICATIONS

Model	W-SC6	W-SC10
Supply includes	Sound shield with steel base, mounted on rubber anti vibration mounts. (Generator set without sound shield is optional)	
Dimensions hwxwd	69.0 x 52.5 x 58.0 cm	80.5 x 52.5 x 58.0 cm
Colour	Metallic silver / grey	Metallic silver / grey
Weight	200 kg including sound shield	240kg including sound shield
Max. installation angle	25 degrees	25 degrees
Standard supplies	Digital remote panel (+15 m cable), fuel filter, fuel lift pump, user and installation manuals	
Available as option:	Installation kits, non earth return (ungrounded), spare part kits	

## 2.5.14 Wiring codes and colours

	number	colour	cable code no cross section
battery > starter motor		red	25 mm <sup>2</sup>
starter motor > DCC	1	red	6 mm <sup>2</sup>
starter motor > LCP	13	red	2,5 mm <sup>2</sup>
battery > ground		black	25 mm <sup>2</sup>
ground > LCP ground (GND)	2	black	2,5 mm <sup>2</sup>
DDC > glow plug	3	brown	4 mm <sup>2</sup>
DDC > starter solenoid	4	yellow	2,5 mm <sup>2</sup>
LCP > fuel lift pump +	5	grey	1,5 mm <sup>2</sup>
LCP > fuel lift pump –	15	black	1,5 mm <sup>2</sup>
DDC > LCD	5	grey	1,5 mm <sup>2</sup>
DDC > oil pressure switch	6	purple	1 mm <sup>2</sup>
LCP > oil pressure switch	6	purple/black	1 mm <sup>2</sup>
DDC > oil temperature switch	7	blue	1 mm <sup>2</sup>
LCP > oil temperature switch	7	blue/black	1 mm <sup>2</sup>
DDC > exhaust temperature switch	8	blue/green	1 mm <sup>2</sup>
LCP > exhaust temperature switch	8	blue/pink	1 mm <sup>2</sup>
DDC > fuel solenoid (hold)	9	green	1,5 mm <sup>2</sup>
DDC > fuel solenoid (pull)	20	pink	1,5 mm <sup>2</sup>
DDC > fuel solenoid (com.)	17	black	1,5 mm <sup>2</sup>
B+ terminal alternator > starter motor	21	red	6 mm <sup>2</sup>
DDC > R terminal alternator	18	white	1,5 mm <sup>2</sup>
DDC > L terminal alternator	19	orange	1,5 mm <sup>2</sup>
DDC > current measuring transformer	11	black	1 mm <sup>2</sup>
DDC > current measuring transformer	11	red	1 mm <sup>2</sup>
DDC > LCP	12	black	1,5 mm <sup>2</sup>
DDC > LCP	14	red	1,5 mm <sup>2</sup>
DDC > LCP	16	red/green	1,5 mm <sup>2</sup>
DDC > generator AC output	33	brown	1 mm <sup>2</sup>
DDC > generator AC output	33	blue	1 mm <sup>2</sup>

DDC=Digital Diesel Control Unit

LCP=Local Control Panel

### 2.5.15 Lay outs control wiring

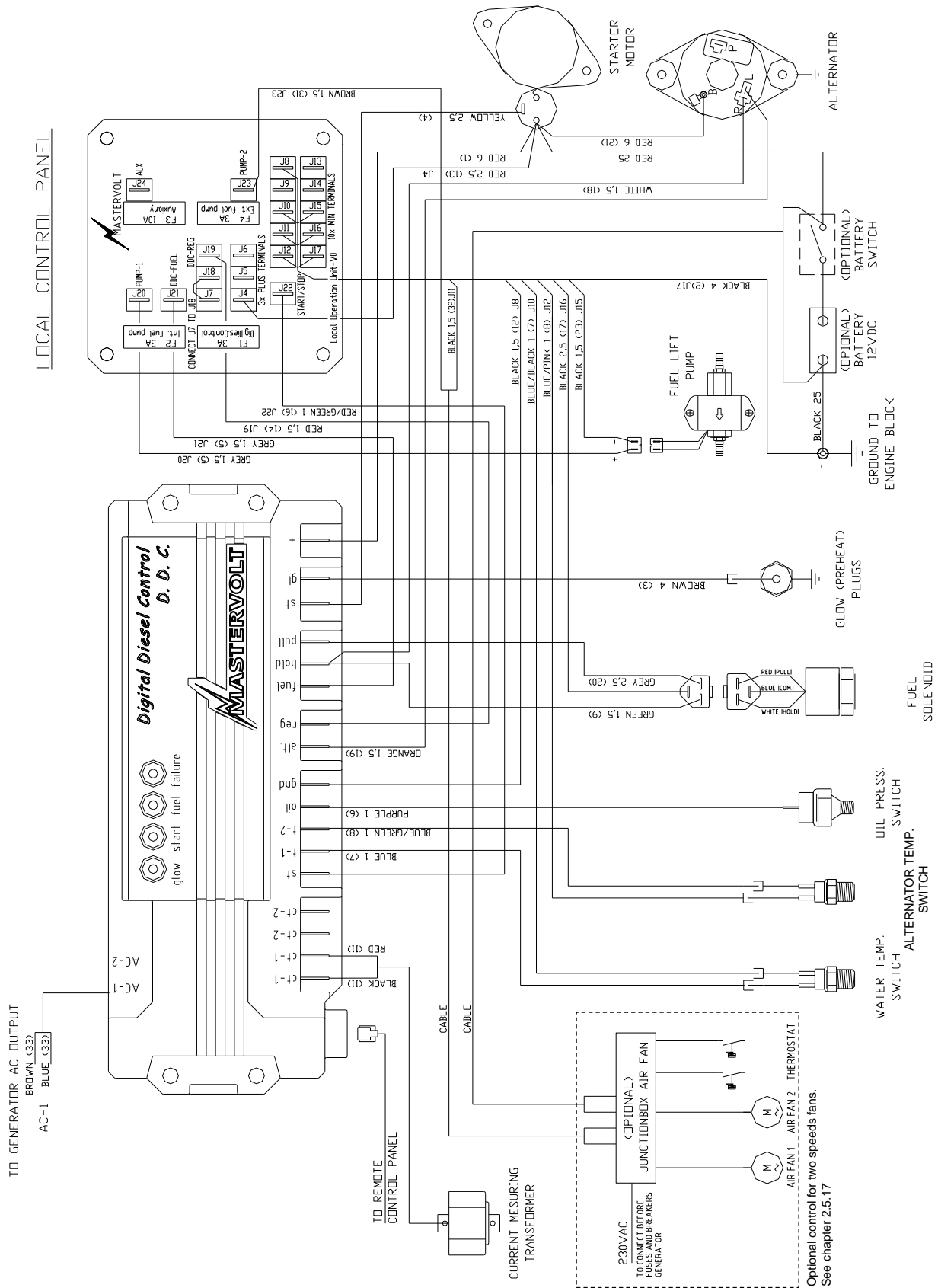

Fig 10: Electrical Diagram control wiring W-SC 6 /SC10, using a 230V AC radiator fan



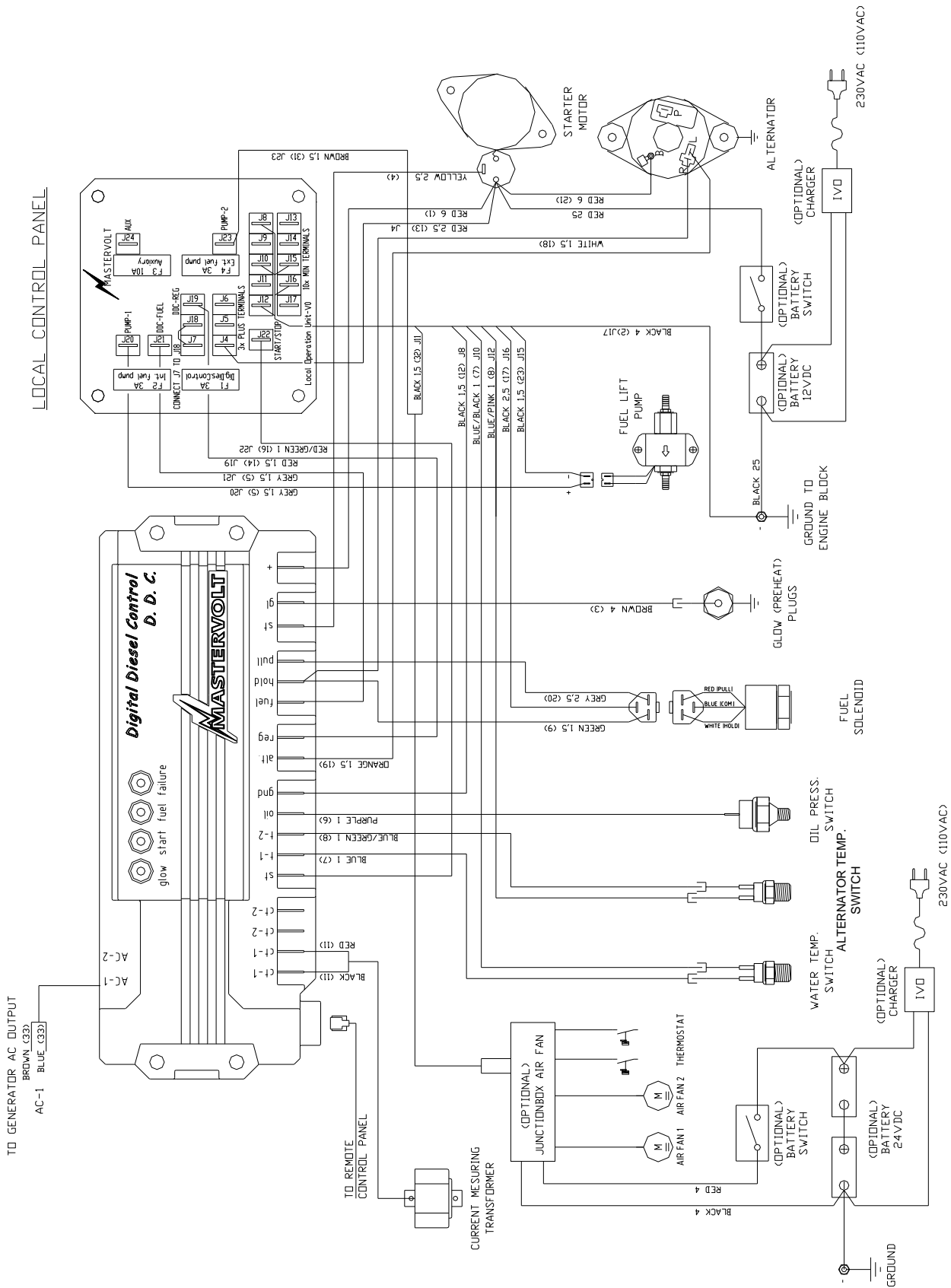

Fig 11: Electrical Diagram control wiring W-SC 6 /SC 10, using a 24V DC radiator fan

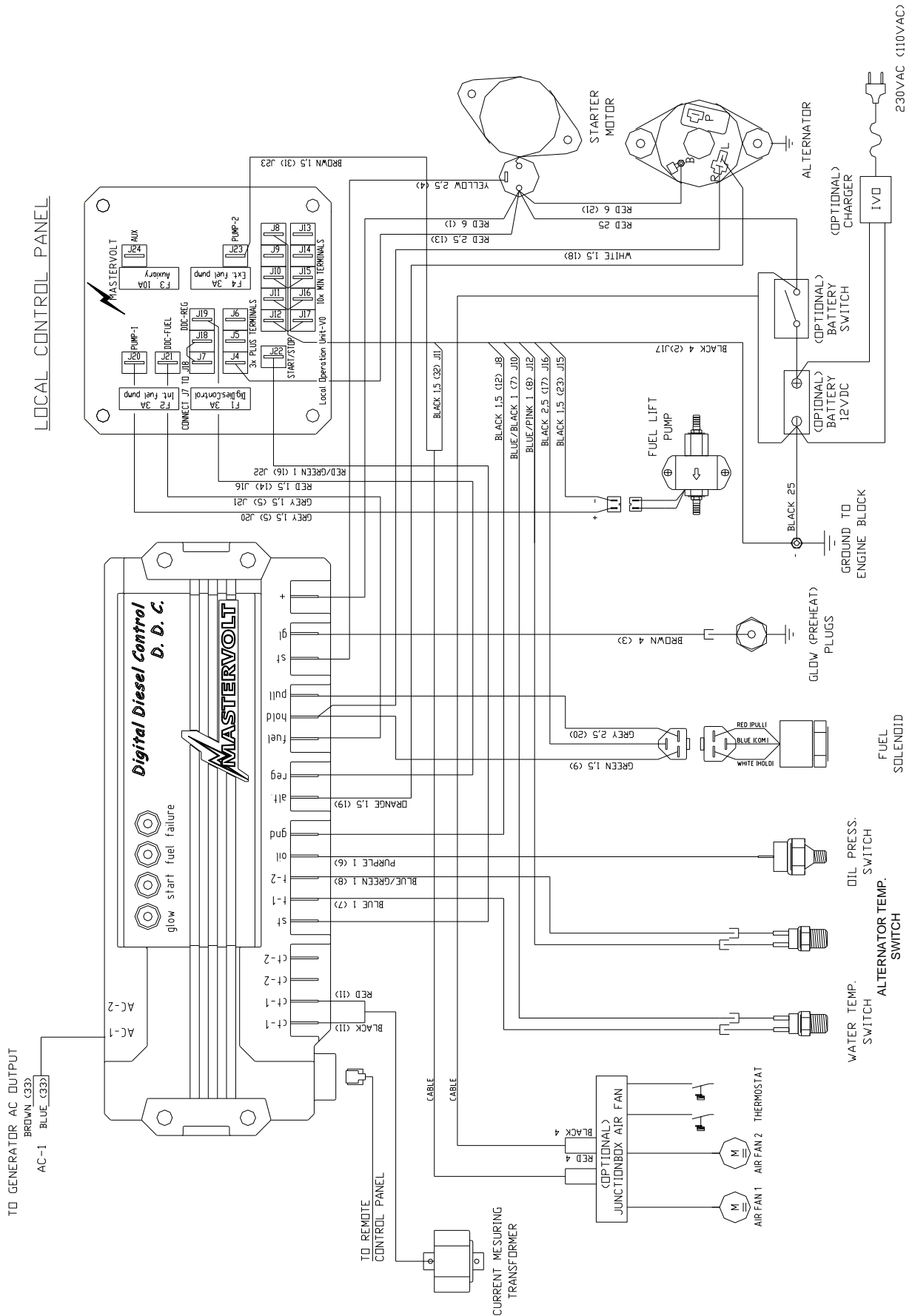
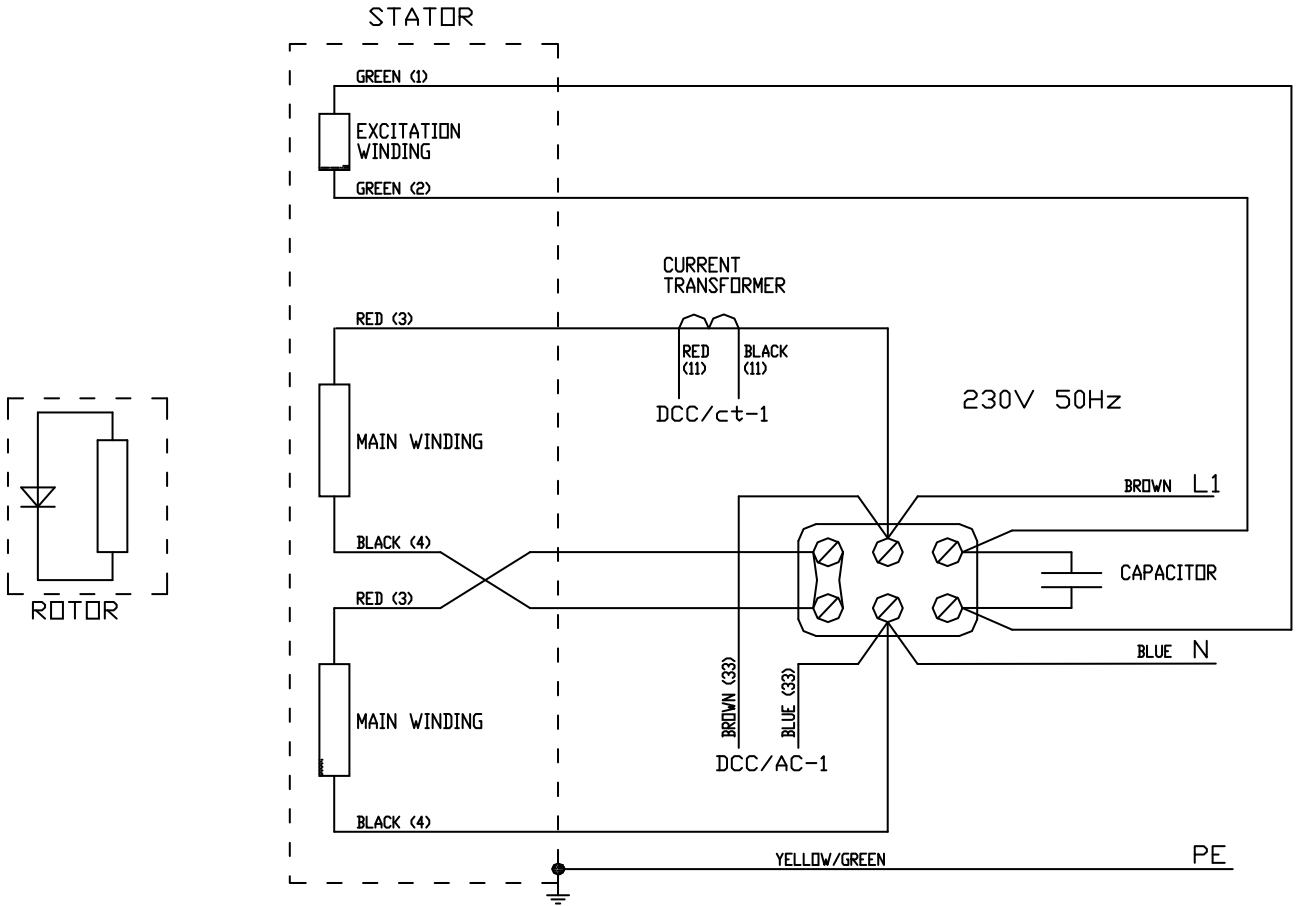

Fig 12: Electrical Diagram control wiring W-SC 6 / SC 10, using a 12V DC radiator fan

2.5.16 Electrical diagrams 230 V AC / 50 Hz

EARTH AND NEUTRAL NOT CONNECTED



EARTH AND NEUTRAL CONNECTED

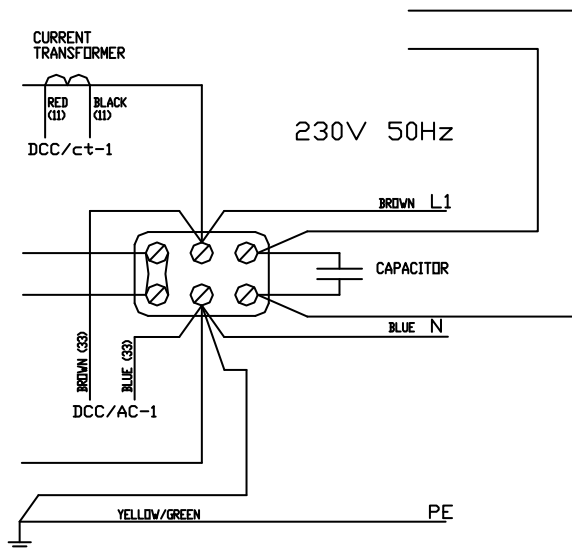

Fig. 13: Electrical diagram 230V

2.5.17 Electrical diagrams radiator fan control

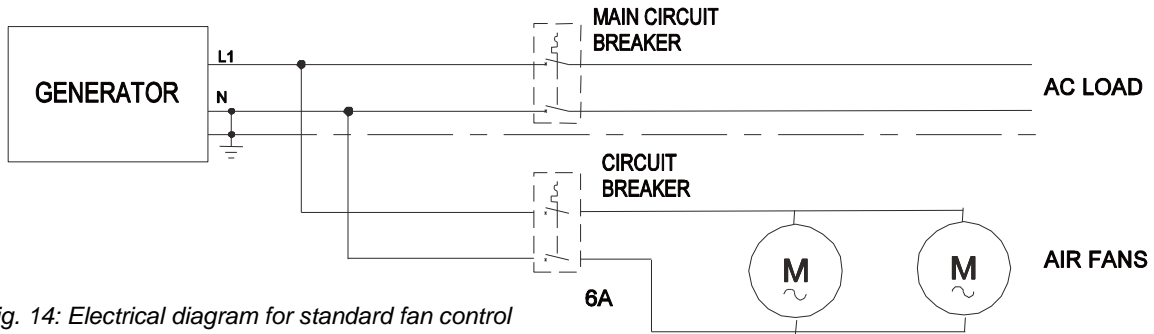

Fig. 14: Electrical diagram for standard fan control using 230V AC radiator fans

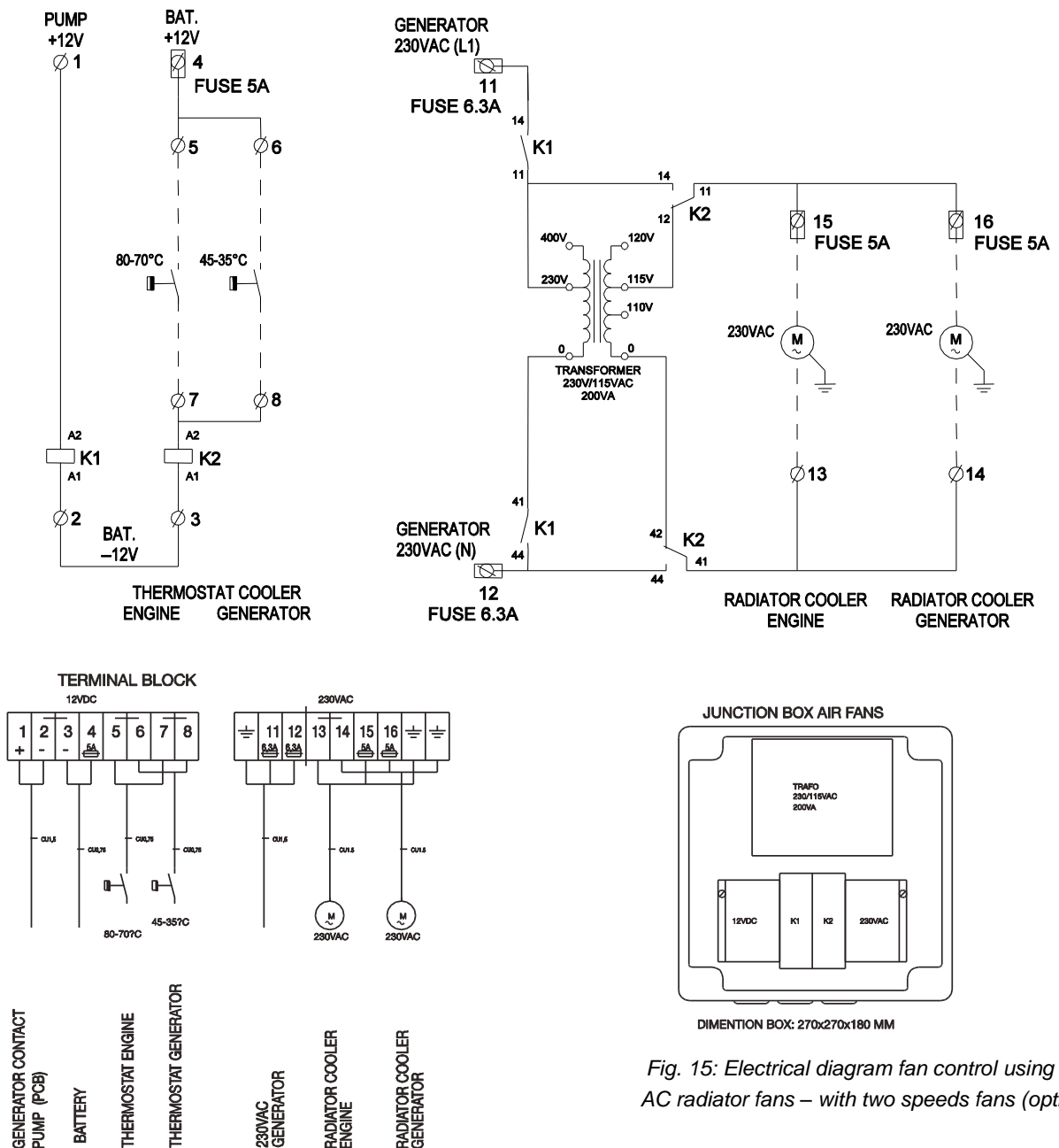

Fig. 15: Electrical diagram fan control using 230V AC radiator fans – with two speeds fans (optional)

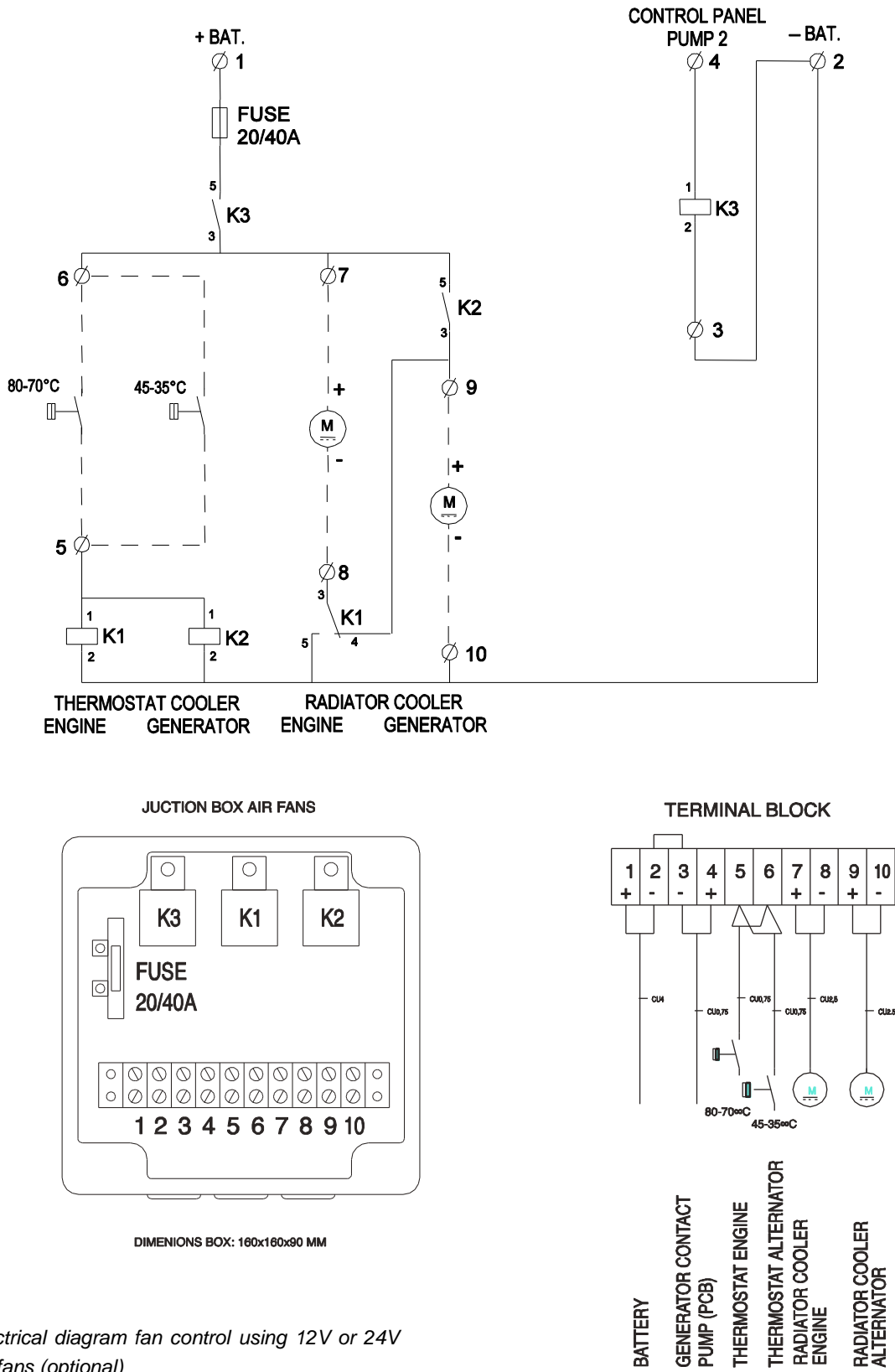

Fig. 16: Electrical diagram fan control using 12V or 24V DC radiator fans (optional)

### 2.5.18 Diagram electronic governor (standard)

In addition to the mechanical governor, the W-SC6 and SC10 are standard equipped with an electronic governor. A governor keeps the speed (RPM=Rotations Per Minute) of the engine at a fixed value. The RPM of the engine correlates with the frequency of the electrical output (3000 RPM =50 Hz) of the alternator.

Under full load the RPM of the Whisper models that have only a mechanical governor can drop 75 RPM (=2.5 Hz) at full load and will go further down or collapse when further loaded. However the engines with the electronic governor will keep the RPM and frequency at the set value. As the voltage is related to the frequency, the voltage will be more stable as well.

The RPM represents power and the alternator performs better as well on a higher speed. Whisper models with an electronic governor will bring more power.

So the electronic governor offers three advantages: a more stable frequency and voltage and more power.

The electronic governor system contains two parts:

- 1 The actuator controls the engine speed. This actuator replaces the standard hold solenoid that is on all other mechanical controlled Whisper engines. The actuator controls the RPM directly on the fuel rack inside the fuel pump without levers and other mechanical transmissions.
- 2 A microprocessor keeps the speed at the set value by controlling the actuator. The microprocessor is programmed at the Whisper Power factory and many parameters are set to perform well. It should not be necessary to make adjustments. When adjustments are necessary this can only be done with the help of an interface to a computer and special software to get access to the microprocessor.

The Whisper Power electronic governor does not need a pickup device in the flywheel housing that counts the passing tooth of the flywheel and determines the exact RPM of the engine, because the processor uses the 50 Hz of the AC output voltage as a reference.

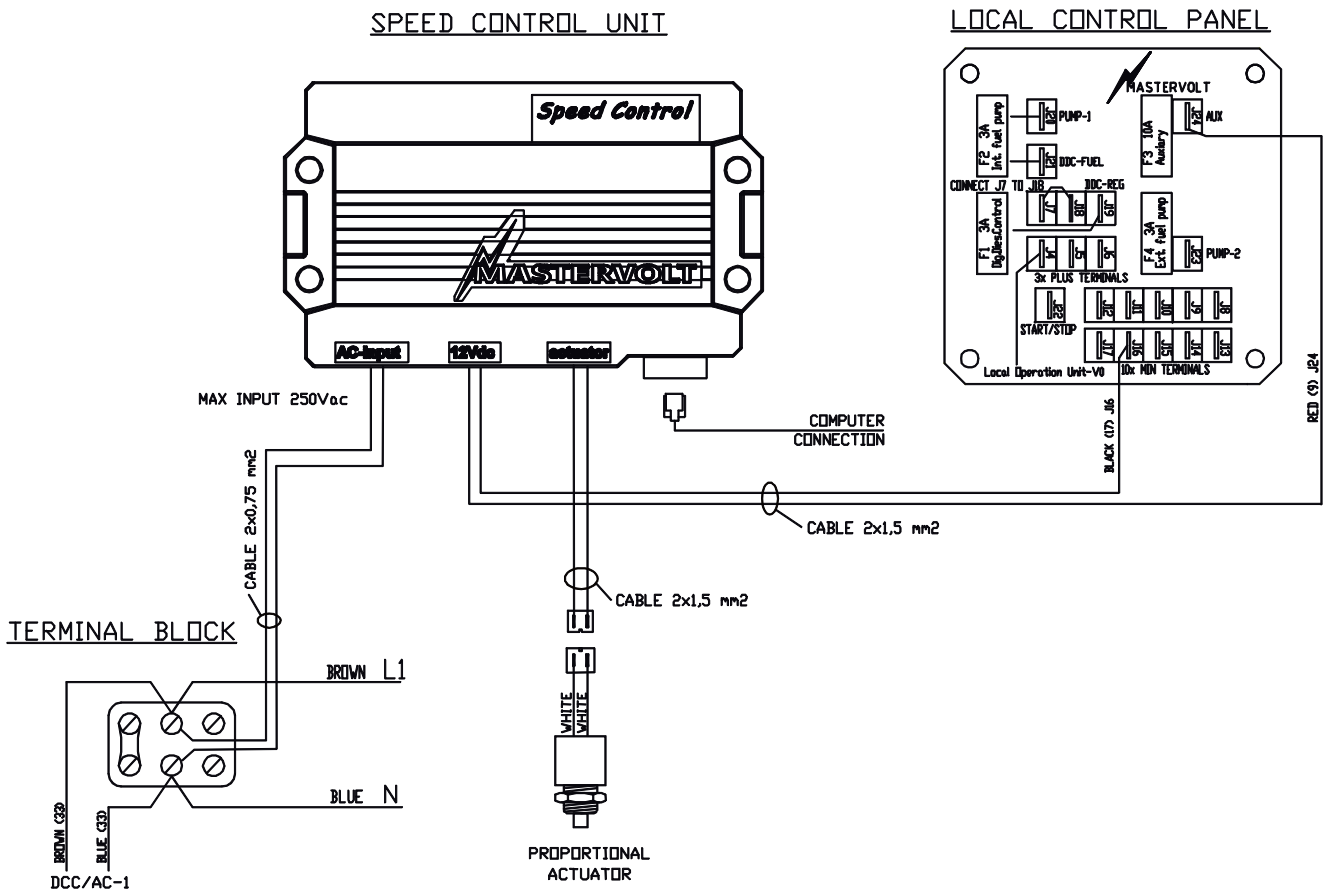
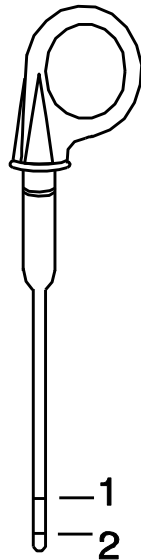

Fig 17: Diagram electronic governor

### 3 OPERATION

#### 3.1 GENERAL

The generating set is operational after full installation and filling up with: fuel, engine lubricating oil and cooling liquid, connecting the battery to earth and connecting the digital remote control panel.



- 1 Maximum oil level
- 2 Minimum oil level

Fig. 18:

#### 3.2 OPERATING INSTRUCTIONS

##### 3.2.1 Summarised operating instructions (daily use)

Routine "pre-start" checks:

- 1 Check oil level (refer to fig. 18).
- 2 Check cooling system (coolant level).
- 3 Power source selector switch (off/external power/generator power). Switch to power source switch "OFF", or switch off all consumers in the usual way. If a Mass Systemswitch is installed, this operates automatically.
- 4 Switch on battery switch (when installed).
- 5 Fuel valve: open.

Starting:

Push the start button to initiate the full automatic starting procedure. You can monitor the procedure on the display.

In operation checks:

- 1 Check for abnormal noise or vibration
- 2 Check the voltage
- 3 Power source selector switch (off/external power/generator power). Switch to power source generator. If a Mass Systemswitch is installed, this operates automatically.
- 4 Before loading the generating set up to maximum, have it run warm. Continuous load should be restricted to 70 % of maximum load.

Stopping generator:

- 1 Switch off all electrical devices (consumers). If the generating set has been running under full load for a longer period, do not shut it down abruptly. Reduce the electrical load to about 30% of the rated load and let it run for approx. 5 minutes.
- 2 Press the STOP button.
- 3 Switch to an other AC power source, if available. If a Mass Systemswitch is installed, this is done automatically.

##### 3.2.2 Extended operating instructions

Check when starting the first time or after a longer period of rest:

- 1 If there is any damage caused by transport or installation.
- 2 Check if the installation conforms to the installation instructions.
- 3 Ensure the generating set is free to turn without obstruction.
- 4 Check all hoses and hose connections for leaks.
- 5 Check all cables and cable end terminal connections.
- 6 Check the engine and generator mounting bolts.

Routine "pre-start" checks:

- 1 Check engine oil level.  
The generator switches off in the event of insufficient oil-pressure. Even when the oil level is too low the oil pressure can be high enough. Do not run the generator with the oil below the lowest mark in the, because a smaller volume of oil will become contaminated considerably quicker than a larger volume. Therefore we recommend daily oil-checks. Check oil level prior to starting the engine or at least 5 minutes after the engine has stopped.

- 2 Check coolant in both expansion tanks.
- 3 Check for leakages.
- 4 If no Mass Systemswitch is used: Switch main Power Source Selector switch to "OFF" or switch off all devices.
- 5 Switch on the battery switch.

#### Starting the generator:

By pushing the start button briefly the electric system is activated, the fuel lift pump starts pumping and the starting procedure will begin (by pushing the Stop button the system is deactivated).

The first time starting up or after running out of fuel it could be necessary to prime the fuel system. (Refer to bleeding fuel system instructions in the maintenance chapter).

A restart protection prevents starting the engine when it is already running, which could cause damage.

#### Checks once the generator is in operation:

- 1 Check for abnormal noise or vibration.
- 2 Check the voltage.
- 3 Power source selector switch (off/external power/generator power). Switch to power source generator. If a Mass Systemswitch is installed, this operates automatically.  
Before loading the generating set up to maximum, have it run warm. The first 50 hours of running the continuous load should be restricted to 70 % of maximum load. Running for long periods at no load or light load in the first 50 hours can cause cylinder glazing and high oil consumption.

#### Engine load during longer operation:

Please ensure that the generating set is not overloaded. Overloading occurs when the electrical load (demand) is so high that the generator cannot be turned around properly by the diesel engine. Overloading causes the engine to run rough, while using oil and excessive fuel and producing soot by the exhaust. The engine can even stop.

The generator should therefore only be loaded at the maximum rated power for short periods (2-3 hours) only!

The high peak current is meant for the ability to start electrical devices that need a high current for starting especially electric motors and compressors (from a still stand state).

In order to prolong the generating set's life expectancy, the nominal electrical demand on the system should be about

70% or the rated generating set's maximum load. Please note this when switching on your electrical devices! Nevertheless, the Whisper 6 / 10 is designed so as not to overheat, even under extreme conditions.

Do not run the generator for very long periods at no load or at very low load. When this is necessary do load the generator at least one hour in 10 hours for minimum 70%. Long term running at too low load will cause the exhaust to be choked by carbon.



Never remove the battery while the engine is running or any electrical cable while the battery is connected in the circuit. Only disconnect the battery with the engine stopped and all switches in "OFF" position

#### Stopping the generating set:

- 1 Avoid stopping of the generator abruptly after a long period of operation at high load! Doing so, you avoid unnecessary thermal load to your generating set!  
Act as follows:  
Prior to switching off the generating set, decrease the generator load (i.e. turn off most electrical users) and let the generator run at low load for approx. 5 minutes to allow the engine to get properly cool (the influent coolant must flow through the system in order to cool the engine).  
If the generator is operating in a hot environment and you do not act as given above, the excessive heat in the engine can trip the "high temp" alarms. In that case, a restart of the engine is not possible for some time. It is also recommended to switch off electrical users prior to stopping the generator because of the voltage drop that occurs as the engine comes to a halt. Such voltage drops may cause damage to electric motors, compressors (in refrigerators or air conditioners etc.).
- 2 Press the STOP button.
- 3 Switch to an other 230V power source, if available. If a Mass Systemswitch is installed, this is done automatically.



If the engine is not running and 'failure' and 'charging' LED is blinking, reset by stop button, otherwise it will drain the start battery



## 4 MAINTENANCE

### 4.1 ALTERNATOR

The alternator does not require any maintenance. Periodic inspection and cleaning is recommended, depending on environmental conditions.

However when the alternator has been idle for a long period attention to winding condition is recommended.

The condition of windings can be assessed by measurement of insulation resistance to earth.

The CAPACITOR should be disconnected during this test. A 500V 'megger' or similar instrument should be used. The insulation resistance to earth of all windings should be in excess of 1.0 MOhm. Should the insulation resistance be less than this value, drying out the generator windings is essential. Drying out can be carried out by direct warm air from a fan heater or similar apparatus into the generator air inlets or outlets.

All bearings are greased for life and not regreasable.

### 4.2 ENGINE

#### 4.2.1 Preliminary instructions

All regular maintenance can be carried out when the enclosure is open. When oil and dirt has gathered in the enclosure measures have to be taken to avoid spilling oil and polluting the environment.

The first service on the engine should be carried out after 50 hours of its life and after a major overhaul. In the first 50 hours the engine should receive special attention:

Long periods of light or no load running in the first 50 hours may lead to cylinder glazing and high oil consumption.



For the same reason it is of the greatest importance to use the right oil specification

The first time starting up or after running out of fuel it could be necessary to prime the fuel system.

#### 4.2.2 Bleeding fuel lines

Ensure there is sufficient fuel. The system is self bleeding. The first time starting up or after running out of fuel it could be necessary to prime the fuel system. Push the start button activating the electric system and activating the fuel pump. When more time is needed to bleed, push "start" and hold on the local control panel (so not on the remote panel) Hold as long as necessary to bleed the system. Retighten the bleed screw when no further air bubbles are expelled.

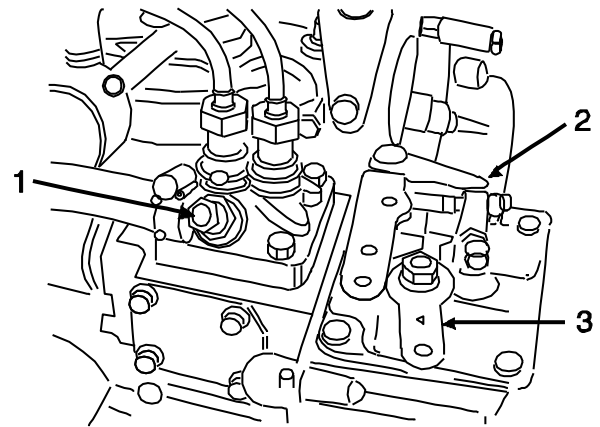

Fig. 19: Bleeding fuel lines 1 = Fuel bleeding screw

#### 4.2.3 Valve clearance

When the engine is in cold condition both valves (inlet and outlet) should have a clearance between 0.25 mm. The adjustment has to be done at TDC (refer to § 5.4.2).

#### 4.2.4 Replacing fuel filter

Filter change depends on contamination of the fuel, but should be done however, at least every 300 running hours. Before changing the filter, clamp off the supply line. Remove the hoses from filter and attach them on the new filter again. The arrow on the filter housing indicates the direction of the flow. A clogged filter results in a lack of output of the generating set.

#### 4.2.5 Replacing oil filter

The oil filter is in front of the service side. Replacement has to be executed according to the schedule in this manual. Drain the oil using the sump pump and put some tissues under the filter.

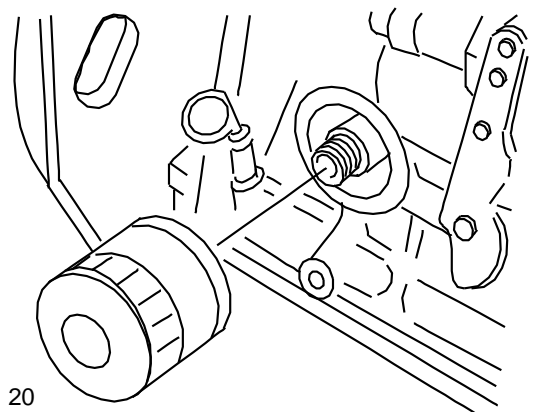

Fig. 20

A smear of oil has to be put on the seal of the filter before fitting the filter. The filter should be fastened manually: when the rubber touches the metal turn 3/4 further.

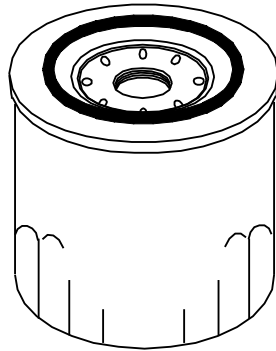

Fig. 21

#### 4.2.6 Readjustment V-beltplacing oil filter

The alternator bracket allows for readjust of the V-belt. Deflections should be 10 mm (refer to fig. 22)

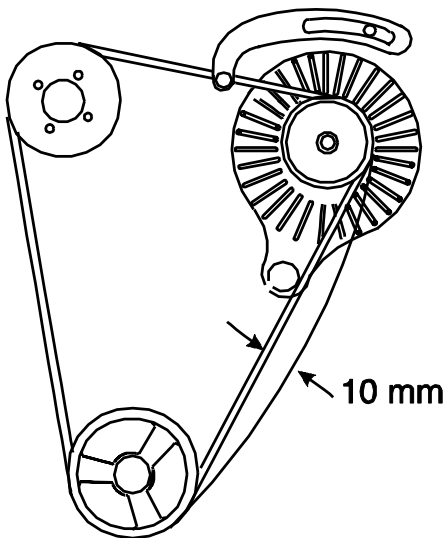

Fig. 22

#### 4.2.7 Air strainer element

The W-SC6 / SC10 for mobile applications is standard supplied with an air strainer element (figure 23). Strainer change depends on environmental contamination. Check the air strainer at least every 500 running hours. The strainer can be cleaned by washing in petrol or solvent

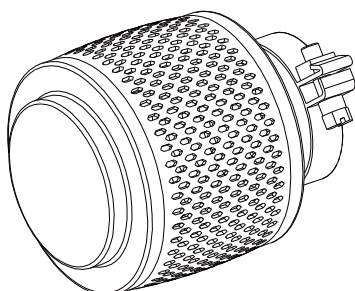

Fig. 23

### 4.3 REGULAR MAINTENANCE

#### CHECK DAILY:

- Oil level (see fig. 24)

Take care the oil level is never below the mark. Do not add oil when the level is still above the mark

- 1 Minimum oil level
- 2 Maximum oil level

Fig. 24:

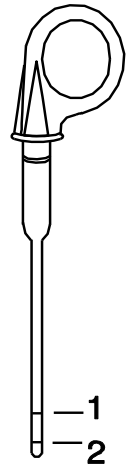

#### CHECK DAILY:

- Level cooling liquid
- Hoses for loose connections or deterioration.

#### AFTER FIRST 50 HOURS:

- Change oil and replace the oil filter.  
Have the engine run until it is on temperature and stop it. Replace the oil filter. Drain oil by the sump pump into a suitable retainer and fill up with fresh oil. Start the engine again and have it run for 5 minutes. Stop the engine again and pause for a few minutes to let the oil gather in the crankcase. Check the level again and add oil when necessary.
- Check and tighten nuts, bolts, and unions, paying particular attention to the fuel system.
- Observe the exhaust at the normal full load. The exhaust must be free from soot. Do not allow the engine to run with a dirty exhaust without investigating the cause as this may result in an expensive breakdown.
- Check and readjust V-belt.
- Check the electrical connections.

#### EVERY 150 HOURS:

- Change oil.
- Check the battery acid level (not applicable when Whisper Power batteries are used).
- Check battery terminals for corrosion
- Check and readjust V-belt

**EVERY 300 HOURS:**

- Check the impeller of the alternator coolant pump.
- Replace the oil filter.
- Replace the fuel filter  
Replacement depends on the condition of the fuel. We recommend replacement every 300 hours. Isolate the fuel supply and change the element.

**EVERY 500 HOURS:**

- Check the air strainer element
- Replace the impeller of the alternator coolant pump.

When replacing the impeller the gasket between the pump case and the cover should be replaced as well. So when ordering a spare impeller order a gasket as well. Remove the cover to get access to the impeller. Remove the old impeller with the help of two screwdrivers. Install the new impeller and add some grease. Turn the blades in the direction of rotation of the pump i.e. anti clockwise looking at the impeller.

**EVERY 1000 HOURS:**

- Replace the V-belt.
- Retighten the cylinder head bolts and adjust the valve clearance. (Refer to § 5.4.2).
- Check and clean the radiators

**EVERY 2000 HOURS:**

- Check lubricating oil pressure
- Clean and check or replace fuel injector nozzles and check injection pressure.
- Check the air filter element:  
The air is taken in via the cover on the alternator. Below this cover is a spongy material which filters the air and holds some electrical components which are cooled by the inlet air. This filter does not require regular maintenance. Only in very dusty circumstances this filter should be cleaned. The spongy material can be washed in solvent or replaced.



When the generator set runs less than 100 hours a year the oil should be changed yearly

**4.3.1 Maintenance schedule**

Check oil level	daily
Check the level of the cooling liquid	daily
Change oil and oil filter	after first 50 hours
Check and tighten nuts, bolts, etc.	after first 50 hours
Check exhaust	after first 50 hours
Check and readjust V-belt	after first 50 hours
Check electrical connections	after first 50 hours
Change oil	150 hours
Check battery	150 hours
Check and readjust V-belt	150 hours
Check impeller water pump	300 hours
Replace oil filter	300 hours
Replace fuel filter	300 hours
Replace impeller coolant pump	500 hours
Check the air strainer element	500 hours
Replace the V-belt	1000 hours
Retighten cylinderhead bolts and readjust valve clearance	1000 hours
Check and clean radiators	1000 hours
Check lubricating oil pressure	2000 hours
Check injector and injection pressure	2000 hours
Replace or clean the air inlet strainer	2000 hours

**4.3.2 Putting out of service**

When not using the generating set for a longer period it is recommended to execute an engine preservation procedure.

- 1 Clean the engine.
- 2 Loosen the fuel suction pipe and fuel return and put them in a can with preservation diesel fuel. Start the engine and run the engine warm.
- 3 Drain the hot engine oil and refill with preservation oil.
- 4 Stop the engine.
- 5 The coolant can stay in the engine
- 6 Disconnect the battery and store it in a place free of frost and dry and charge it regularly.
- 7 Close inlet- and outlet openings with tape.
- 8 Protect the generating set against the influences of bad weather conditions.

This method of preservation will be sufficient for 6 months. Repeat steps 2, 3, and 4, every 6 months. Change oil before using the engine again.

## 5 TROUBLE SHOOTING

### 5.1 ALTERNATOR/ ELECTRICAL FAULTS



Beware of parts which are live!



Remove 3 Amp. Fuse in the control panel while working on the generator to prevent the engine from starting

A failure code is displayed when a hardware failure at the generator is detected

#### 5.1.1 General

If any problem should occur, check basic conditions and examine all external wiring, switch gear and circuit breakers. Also check if measuring instruments give the correct value. If in doubt, measure directly on the alternator terminals with an independent instrument.

If during these measurements the engine immediately stops after starting and an error code is displayed at the

remote control panel ( "AC VOLTAGE"), one can start the generator by means of a "service start" at the service menu (see paragraph "service start" of the user's manual of the Digital Diesel Control). By doing this, the generator will keep running for 2 minutes before it stops. This offers you the possibility to carry out measurements to investigate the cause of the failure. This should only be carried out by an experienced electrician.

Check if the engine is running correctly at 3000 RPM (50 Hz) according to its settings and does as well under load. A RPM drop of 1% at full load is acceptable. Therefore a no load setting should be at 3030 RPM = 50.5 Hz. Under no circumstances should the RPM under full load be below 2970 RPM = 49.5 Hz.

When the problem is in the RPM refer to the engine fault finding paragraph.

Digital Diesel Control system will help to indicate failures and display causes.

<i>Failure code</i>	<i>Problem</i>
<b>COMMUNICATION</b>	Communication error between the panel end the generator
<b>LOW START BAT</b>	Starter battery voltage too low
<b>ALTERNATOR</b>	No output battery charging voltage
<b>AC-ALTERN. TEMP</b>	AC-alternator temperature is too high
<b>WATER TEMP</b>	Coolant temperature is too high
<b>OIL PRESSURE</b>	Oil pressure failure
<b>AC VOLTAGE</b>	Generator AC output voltage is either too high or too low
<b>HIGH CURRENT</b>	Generator is in overload
<b>FREQUENCY</b>	Output frequency of the generator is too low

#### 5.1.2 Trouble shooting table alternator

<b>PROBLEM</b>	<b>CAUSE</b>	<b>SOLUTION</b>
No output (Voltage) at all	• Circuit breaker "off" or faulty fuse	Check switches and fuses and measure directly on the alternator to exclude external causes.
	• Low engine RPM.	Check the engine RPM and adjust (refer to special procedures).
	• Loss of residual magnetism.	Check the residual magnetism and flash the alternator (refer to special procedures).
	• Capacitor loose or broken.	Check by independent excitation if the problem is in the capacitor or in the windings.
	• Rotor diodes broken.	Check the diode in the rotor (refer to special procedures). The Whisper 6 / 10 has one diode in the rotor.
Generator output voltage too low when no load is on it (less than 210V/105V)).	• No load at all or very low load.	Switch on a load and check voltage.
	• Engine is not reaching the rated RPM.	Refer to special procedures to readjust RPM.
	• Defective capacitor.	Check capacitor and replace if necessary (refer to special procedures).
	• Defective diode	Check the diode in the rotor and replace (refer to special procedures).

<b>PROBLEM</b>	<b>CAUSE</b>	<b>SOLUTION</b>
Generator output voltage too low under load (less than 210V/105V). In no load condition it is ok	<ul style="list-style-type: none"> <li>• Generator is overloaded.</li> <li>• Engine is not reaching the rated RPM.</li> <li>• Defective capacitor</li> </ul>	Switch off a load; (part off) consumers. Refer to engine RPM problems Check capacitor and replace if necessary (refer to special procedures).
Generator voltage too high, (more than 245V/130V)	<ul style="list-style-type: none"> <li>• Engine is running too fast (RPM too high).</li> <li>• Over-energising due to defective capacitors</li> <li>• Presence of a strong capacitive load (leading power factor)</li> </ul>	Check engine speed and adjust (refer to special procedures). Check capacitor specification and replace capacitors if necessary. Compensate for this capacity and seek for experts advice (WHISPER POWER customers service)
Generator voltage fluctuates.	<ul style="list-style-type: none"> <li>• Disturbances on the electrical system/ user side.</li> <li>• Engine runs irregularly.</li> </ul>	Check if electrical load is fluctuating When engine runs irregularly refer to section: "Engine runs irregularly".
Generator is not able to start an electric motor	If the generator is unable to supply enough power to start an AC electric motor, this is usually because this motor draws too much current during starting	Check the electric motor's current draw required for starting. This should not exceed the rated generator peak output current. This could be remedied by providing stronger capacitors to the motor or using a "soft-start". Inquire at your nearest Whisper Power dealer or directly at the manufacturer, Whisper Power in the Netherlands.

## 5.2 ENGINE FAULTS



Remove 3 Amp. fuse in the control panel while working on the generator to prevent the engine from starting.

### 5.2.1 General

Most electrical problems relating to Voltage or Frequency are due to wrong engine speed. Note that RPM and Hz are basically the same.

Use the problem solving table to find the cause of a wrong engine speed. When there is no obvious cause one can adjust the RPM (refer to special procedures).

When the engine is not cranking well, starting problems almost always originate from battery problems or poor battery cable connections.

When the engine is cranking, well starting problems almost always originate from lack of fuel or air bubbles in the fuel pipes.

A failure code is displayed when a hardware failure at the generator is detected.

<b>Failure code</b>	<b>Problem</b>
<b>COMMUNICATION</b>	Communication error between the panel end the generator
<b>LOW START BAT</b>	Starter battery voltage too low
<b>ALTERNATOR</b>	No output battery charging voltage
<b>AC-ALTERN. TEMP</b>	AC-alternator temperature is to high (generators for mobile applications only)
<b>WATER TEMP</b>	Coolant temperature is too high
<b>OIL PRESSURE</b>	Oil pressure failure
<b>AC VOLTAGE</b>	Generator AC output voltage is either too high or too low
<b>HIGH CURRENT</b>	Generator is in overload
<b>FREQUENCY</b>	Output frequency of the generator is too low

### 5.2.2 Trouble shooting table engine

PROBLEM	CAUSE	SOLUTION
Diesel engine fails to crank, the starter makes clicking noises, or the engine cranks very slowly	<ul style="list-style-type: none"> <li>• Almost certainly this is an electrical problem. Display will indicate "LOW START BAT"</li> </ul>	The problem must be an electric malfunction.
	<ul style="list-style-type: none"> <li>• Starter battery switched "OFF".</li> </ul>	Check position of the battery switch and switch "ON".
	<ul style="list-style-type: none"> <li>• Starter battery voltage insufficient (battery too weak).</li> </ul>	Check battery voltage. Recharge the battery. Inspect battery terminals and cables for a good electrical connection (inspect against corrosion, tattered wires, etc.)
	<ul style="list-style-type: none"> <li>• Faulty fuse on the control panel</li> </ul>	Replace fuse
	<ul style="list-style-type: none"> <li>• Wiring control system faulty</li> </ul>	During the normal starting process, the battery voltage drops to 11V (with a fully charged battery). If the voltage does not drop during starting, the electrical connection is faulty. If the battery voltage drops lower than 11V, then the battery has been discharged too deep.
	<ul style="list-style-type: none"> <li>• Starter broken</li> <li>• To thick engine lubricating oil.</li> </ul>	Repair the starter motor Change oil for a lower viscosity.
Starter is turning engine smoothly, but engine fails to start	<ul style="list-style-type: none"> <li>• Out of fuel or faulty fuel, water in the fuel.</li> </ul>	Fill up with fuel or replace with better quality.
	<ul style="list-style-type: none"> <li>• Fuel solenoid is not opening (no "click" can be heard).</li> </ul>	Check wire connections and circuitry to solenoid. (Refer to DC wiring diagram)
	<ul style="list-style-type: none"> <li>• Fuel lift pump is not working.</li> </ul>	Check fuel filter and fuel lift pump: clean or replace if necessary.
	<ul style="list-style-type: none"> <li>• Fuel filter is blocked.</li> </ul>	Bleed air from fuel system (refer to maintenance section).
	<ul style="list-style-type: none"> <li>• Air in fuel lines.</li> </ul>	Bleed air from fuel system (refer to maintenance section).
	<ul style="list-style-type: none"> <li>• Wrong valve clearance.</li> </ul>	Adjust valve clearance,
	<ul style="list-style-type: none"> <li>• Low compression because of dirty valves.</li> </ul>	Clean valves. Take off the injection bent and inspect the outlet port. When little rust in the port clean the valve by taking off the valve spring and rotate until rust is removed. When the outlet port is strongly affected by rust, the exhaust system is not properly installed (refer to paragraph 5.4.3). Contact Whisper Power service department for advice.
<ul style="list-style-type: none"> <li>• Blocked injector.</li> <li>• Loss of compression by wear out or damage</li> </ul>	Have the injector tested and cleaned if necessary. Repair by Whisper Power service	
Engine runs irregularly.	<ul style="list-style-type: none"> <li>• Unsuitable contaminated fuel</li> </ul>	Fill up with fuel or replace by better quality.
	<ul style="list-style-type: none"> <li>• Lack of fuel.</li> </ul>	Fill up with fuel or replace by better quality.
	<ul style="list-style-type: none"> <li>• Choked fuel filter.</li> </ul>	Check fuel filter and fuel lift pump: clean or replace if necessary.
	<ul style="list-style-type: none"> <li>• Disturbances on the electrical system/ user side.</li> </ul>	Check if electrical load is fluctuating
	<ul style="list-style-type: none"> <li>• Faulty fuel lift pump.</li> </ul>	Check and repair
	<ul style="list-style-type: none"> <li>• Choked air filter.</li> </ul>	Check the air intake
	<ul style="list-style-type: none"> <li>• Lack of air.</li> </ul>	Check the air intake
	<ul style="list-style-type: none"> <li>• Choked exhaust system, exhaust blocked,.</li> </ul>	Check the exhaust piping; inspect manifold inside
	<ul style="list-style-type: none"> <li>• Air in the fuel pipes</li> </ul>	Bleed air from fuel system (refer to maintenance section).
	<ul style="list-style-type: none"> <li>• Faulty electronic governor</li> </ul>	Replace faulty parts. Contact Whisper Power service department for advice
	<ul style="list-style-type: none"> <li>• Blocked injector.</li> </ul>	Have the injector tested and cleaned if necessary.
	<ul style="list-style-type: none"> <li>• Wrong valve clearance.</li> </ul>	Adjust valve clearance.
	<ul style="list-style-type: none"> <li>• Temporarily hunting (this will disappear when engine has run in).</li> <li>• Ongoing hunting caused by faulty electronic governor</li> </ul>	Replace faulty parts. Contact Whisper Power service department for advice

PROBLEM	CAUSE	SOLUTION
Engine speed drops	• Faulty electronic governor	Replace faulty parts. Contact Whisper Power service department for advice
	• Too much oil.	Drain oil to proper level
	• Lack of fuel.	Check fuel supply system: fuel pump and filter.
	• Lack of intake air.	Check air intake.
	• Choked exhaust system, exhaust blocked.	Check the exhaust piping; inspect manifold inside
	• Generator overloaded	Reduce the electrical load (switch off some consumers).
	• Generator over energised.	Check that the proper capacitor type is installed and that it is connected correctly.
	• Defective generator (windings, bearings or other)	Generator must be sent to manufacturer for repair of damaged bearing or winding.
	• Damaged engine	Repair by Whisper Power service
Engine does not stop on command	<ul style="list-style-type: none"> <li>• Fuel solenoid is not switching off</li> <li>• Loss of control</li> </ul>	Faulty Digital Diesel Control unit. Stop the engine manually by the stop handle. Check wire connections to stop solenoid. Check solenoid valve function. Replace if necessary
Engine exhaust smokes	• Faint blue smoke - generally the result of light load	Increase load.
	• Heavy blue smoke - caused by lubricating oil: Overfull oil sump or worn cylinder bore, stuck broken or worn rings.	Check the oil level. Check the compression.
	• Black smoke –incomplete combustion caused by: Overload, choked air filter, inlet temperature too high, unsuitable fuel or water in fuel.	Check the fuel . Check for overload.
Engine starts, but stops after 10 up to 30 seconds	<ul style="list-style-type: none"> <li>• Protection system stops the engine; this can be caused by oil pressure failure, lack of cooling water (exhaust temperature alarm). Overload, loose wire or faulty alarm switch. Digital Diesel Control will help to indicate failure.</li> </ul>	Refer to paragraph 2.5.5. and 3.2.2 for information on the alarm system. Bypassing the switches can help to confirm the failure.
Engine stops by itself	• Overload or short circuit.	Switch off the consumers and test for short circuit.
	• Lack of fuel.	Check fuel supply system: fuel lines, pump, filter, valves, tank level, etc.
	• Oil pressure low. (oil pressure switch tripped).	Check oil level. Check engine's oil pressure and have it repaired by Whisper Power.
	• Excessive heat in cooling system (thermo-switch tripped).	Check cooling water system flow: water pump, coolant flow.
	• Lack of cooling water (exhaust switch tripped).	
	• Impeller broken.	
	• Cooling water blocked.	
	• Air or water in the fuel.	Check and clean
	• Blocked air or fuel filter.	
	• Loss of compression by wear out or damage.	Repair by Whisper Power service.
• V-belt broken or loose.	Readjust or replace V-belt	
• Thermostat faulty	Check thermostat and replace	
Sooty, black exhaust.	• Generator is being overloaded. Digital Diesel Control will indicate "HIGH CURRENT".	Check electrical load and switch off some consumers
	• Insufficient intake air.	Check intake air paths and filter, clean and replace if necessary.
	• Choked air filter.	
	• Fuel injector faulty.	Replace injector.
	• Valve clearance incorrect.	Readjust valve clearance

PROBLEM	CAUSE	SOLUTION
	<ul style="list-style-type: none"> <li>Poor fuel quality.</li> <li>Poor quality lubricating oil.</li> <li>Continuous running with very low load.</li> </ul>	<ul style="list-style-type: none"> <li>Use better quality diesel.</li> <li>Use better quality oil.</li> <li>Increase load and have the engine run for a few hours</li> </ul>
Loss of power	<ul style="list-style-type: none"> <li>Wrong measurement. Check if the load is measured correctly. Does the Amp meter show the correct value? When calculating the load by multiplying voltage and amps this should be done by using the exact values, taking into account the power factor of the consumers. When any doubt, measure the power directly with an appropriate instrument.</li> <li>Overfull oil sump.</li> <li>Choked fuel filter.</li> <li>Choked air filter.</li> <li>Exhaust blocked.</li> <li>Injector blocked.</li> <li>Loss of compression, sticking or damaged piston ring.</li> <li>Wear out of cylinder.</li> </ul>	<ul style="list-style-type: none"> <li>Bring the oil to the correct level</li> <li>Replace the fuel filter.</li> <li>Check air inlet openings; clean air filter.</li> <li>Check the exhaust system.</li> <li>Have the injector checked.</li> <li>Have the compression measured. Clean or replace the rings.</li> <li>Have the compression measured and have the engine overhauled.</li> </ul>
Over-temperature	<ul style="list-style-type: none"> <li>Overload.</li> <li>Low level of coolant or air in the cooling system</li> <li>Broken impeller.</li> <li>Radiator choked by dirt</li> <li>Hot air circulation in radiator.</li> <li>Broken or slipping V-belt.</li> <li>Faulty thermostat</li> </ul>	<ul style="list-style-type: none"> <li>Take away the overload.</li> <li>Fill up with coolant and release air bubbles. Check if there are air blocks in the system; refer to the installation manual</li> <li>Check the cooling system thoroughly. Clean radiator</li> <li>Replace and adjust the V-belt tension.</li> <li>Check the thermostat or replace.</li> </ul>

### 5.2.3 Warnings



Generator must be shut off immediately if:

- Motor RPM suddenly rises or drops.
- Unusual noise comes from generating set.
- Exhaust gases suddenly colour dark.
- Engine failure warning light is on

### 5.2.4 Service address

If you cannot correct a problem with the aid of the malfunction table, contact your Whisper Power Service Centre or Whisper Power Netherlands for an extended service list, tel: INT +31-512-571550.



### 5.3 SPECIAL PROCEDURES ALTERNATOR

#### 5.3.1 Residual voltage check / excitation procedure

When residual magnetism disappears there is no residual voltage. Residual magnetism can disappear after the generating set being out of service for a long period or a short circuit. This can be solved by charging the capacitor ("flashing") independently with a small 9 Volt battery. This can be done while the engine is stationary and the wiring is connected.

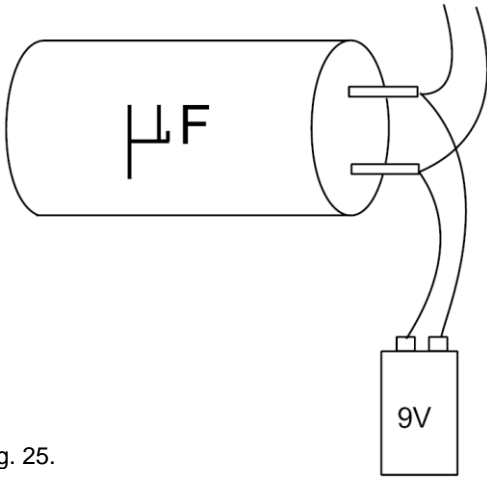

Fig. 25.



If the generating set battery is used for flashing one must take care. A short circuit can cause heavy sparking, fire and injuries

When flashing does not bring back voltage, the capacitor(s) should be renewed. When this does not help, the rotating rectifier diodes should be tested and a winding resistant test should be executed.

#### 5.3.2 Testing rotary rectifier diodes

The diodes in the rotor can be checked with a multimeter. When the diode is faulty the alternator will not generate any voltage.

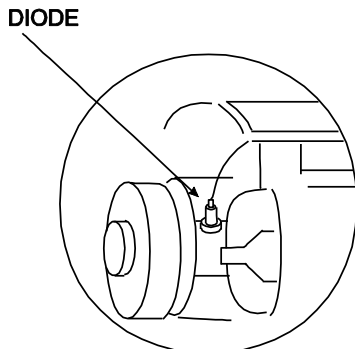

Fig. 26

The flexible lead connected to the diode should be disconnected at the terminal end, and the forward and reverse resistance checked. A healthy diode will indicate a very high resistance (infinity) in the reverse direction, and

a low resistance in the forward direction. A faulty diode will give a full deflection reading in both directions with the test meter on the 10,000 ohms scale, or an infinity reading in both directions. Replace the diode.

#### 5.3.3 Winding resistant values

If after establishing and correcting any fault on the capacitor and diode output is still low when separately excited, then the main rotor, stator and exciter stator winding resistance should be checked as the fault must be in one of these windings. The respective leads must be disconnected before taking the readings.

Resistance values should be within 10% of the values given in the table below:

##### Whisper 6

Resistance	50Hz
• Resistance both main stator windings in series	0.54 Ohm
• Resistance both rotor windings	0.93 Ohm
• Resistance exciter stator winding	1.4 Ohm

##### Whisper 10

Resistance	50Hz
• Resistance both main stator windings in series	0.36 Ohm
• Resistance both rotor windings	1.05 Ohm
• Resistance exciter stator winding	0.85 Ohm

#### 5.3.4 Meggering

One can try to measure resistance between the housing and the windings with a multimeter which should read infinity. When readings are infinity but a fault is suspected one can do a high voltage resistance test (MEGGERING) This procedure should be carried out by an expert

## 5.4 SPECIAL PROCEDURES ENGINE

### 5.4.1 Setting the RPM

RPM is set by the manufacturer and should not need readjustment! When adjustments are necessary this can only be done with the help of an interface to a computer and special software to get access to the microprocessor. If readjustment of the RPM is necessary, please contact your Whisper Power Service Centre for advice.

### 5.4.2 Adjusting valve clearance and retightening the cylinder head bolts.

Both procedures have to be carried out with a cold engine. When both procedures are carried out be sure to retighten the cylinder head bolts before adjusting the valve clearance. When retightening the cylinder head bolts, drain the coolant by removing the drain plug (ref. to fig. 3 till 6).

Loosen the bolts slightly, remove the rocker assembly (the rocker arms, shaft, and stays) and then retighten the bolts to the specified torque in the numerical order illustrated (ref. to fig. 27).

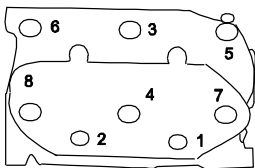

Fig 27a  
Whisper 6

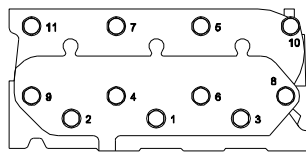

Fig 27b  
Whisper 10

Tightening torque:	M10 bolt 75-85 Nm M8 bolt 20-30 Nm
Rocker stay tightening torque:	M8 bolt 15-22 Nm

The clearance of both (intake and exhaust) valves should be 0.25 mm in cold condition.

- 1 Set the piston of the first cylinder to be adjusted to top dead centre (T.D.C.) of compression stroke.
- 2 The T.D.C. of compression stroke can be found by aligning the T.D.C. mark (notch) on the crankshaft pulley with the mark on the gear case (ref. to fig. 20).

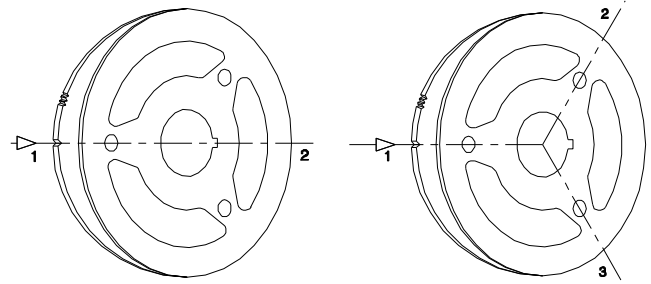

Fig. 28a:  
2 cylinder engine

Fig. 28b:  
3 cylinder engine

- 3 First align the T.D.C. mark for the No. 1 cylinder. Confirm that the valves do not move up or down when the crankshaft is turned about 20 degrees in normal and reverse direction of rotation. If the rocker arms move piston no.1 is on the T.D.C. of the intake or exhaust stroke. In such case turn the crankshaft 360° in the direction of engine rotation again. No. 1 piston is now at T.D.C. of the compression stroke.
- 4 To adjust the valve clearance of the No. 2 and No.3 cylinder
  - a. Two cylinder engine (W-SC6): the crankshaft pulley has to be turned 180 degrees clockwise to set this piston to T.D.C. Adjustment can be executed.
  - b. Three cylinder engine (W-SC10): After adjusting the valves of cylinder 1 turn the crankshaft 240 degrees clockwise from the T.D.C of cylinder 1 to the T.D.C of cylinder 3. Position 2 fig. 28b against the notch. Adjust the valves of cylinder 3. Then turn the crankshaft 240 degrees further clockwise to the T.D.C of cylinder 2 and adjust the valves; position 3 fig. 28b against the notch.

Check after each adjustment that the valves do not move up and down when turning the crank craft about 20 degrees clockwise and counter clockwise of T.D.C

### 5.4.3 Disassembling instructions

It could be necessary to disassemble the generating set for repair or checks. Following instructions will help:

- 1 The design of the W-SC6 / SC10 makes it possible to do most repairs on the spot. The connections of the alternator are very accessible. The same is true for the diode of the rotor
- 2 The sound shield can be disassembled according to exploded view below (figure 30).
- 3 To take the generating set out of the canopy all hose and cable connections have to be taken off. The set is fixed to its base by four rubber mountings and can be loosened by removing the four nuts from the bolts of these mountings and by removing the safeguards. The easiest way to get the generator out of its capsule is by lifting the set with the aid of the lifting eyes.

- 4 One can take off the complete alternator housing. Before the alternator can be taken off all cables and wiring has to be taken loose first.
- 5 The rotor can be taken off by removing the bold which goes through the shaft (normal clockwise threaded). The end of the shaft is specially threaded to push off the rotor from the conic stub shaft, which is on the flywheel, using a 6-mm rod of 165mm length (W-SC6) or 185mm length (W-SC10) and a M10 bolt.
- 6 Reassembling the generating set one should take care of alignment, cleaning the surfaces between engine and alternator and tighten the bolts crosswise and gradually.
- 7 Use Loctite 577 to seal the fittings, which should first be cleaned and made free of oil and grease.
- 8 Test the generating set first outside its capsule and check very carefully for leakages before putting it back in its enclosure.

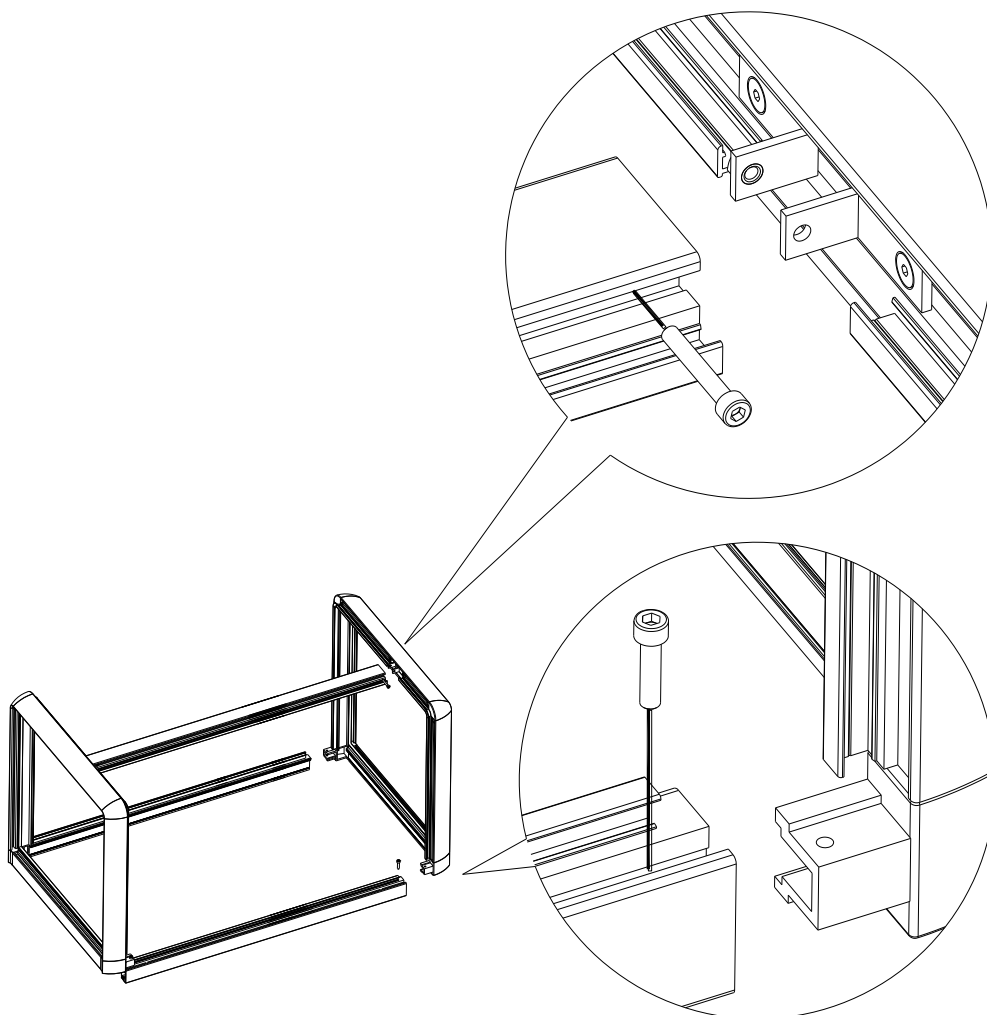

Figure 30: exploded view sound shield W-SC 6 / SC 10

## 6 SPARE PARTS LIST

A complete parts manual in English is available as an option number: number: 40200182 (\*\*\*)

A work shop manual in English is available as an option number: 40200171 (\*\*\*)

We recommend the following spares for service and maintenance.

- Kit A: parts for regular maintenance parts marked (\*) article no. 40201860
- Kit B: parts for maintenance + spare parts: all parts marked (\*)+(\*\*) article no. 40201761

ARTICLE NO	DESCRIPTION
50209030	Fuel filter (*)
50201031	Fuel lift pump
50203120	V-belt (*)
40203121	Oil filter (*)
50201850	Water pump complete Whisper Power type M (refer to fig. 31)
50209011	Impeller (50209013) + gasket (50209012) (*)
40201812	Cover type M (**) (2)
50209018	Bolts cover (**) (6 pcs.)
50201851	Pump repair kit A consisting of: Shaft (50201811), Bearings (2 pcs) (50209014), O-ring (50209017), Seals (2 pcs.) (50209015), Clips (1 set) (50209019), O-ring (50201814)
50209010	Pump repair kit B (**)(same as repair kit A excluding the shaft(50201811) and O-ring (50201814))
50201060	Capacitor xx micro-farad, 2 pcs (**) (xx = give value when ordering)
50209132	Measuring coil
50201890	Rotary diode (**)
50201887	Alternator bearing including O-ring (**)
50209104	Local control panel
50209200	Digital Diesel Control Unit
50212170	Fuses 10 Amps(*)
50212154	Fuses 3 Amps (*)
50201886	Wiring loom complete
50209102	Digital Diesel Remote control panel
130010915	Cable remote control 15 mtr, including connectors
40203033	Overhaul gasket kit / Seal kit for W-SC6
50203030	Cylinder head gasket kit for W-SC6
50204033	Overhaul gasket kit / Seal kit for W-SC10
50204030	Cylinder head gasket kit for W-SC10
50203040	Glow plug, 2 pcs (W-SC6) (**); 3pcs (W-SC10) (**)
50203050	Nozzle injector, 2 pcs (W-SC6 en SC8) (**); 3pcs (W-SC10) (**)
50203160	Fuel pump (high pressure) complete for W-SC6
50204160	Fuel pump (high pressure) complete for W-SC10
50203045	Thermostat (**)
50203038	Gasket thermostat (**)
50203037	Gasket rocker cover for W-SC6 (**)
50204037	Gasket rocker cover for W-SC10 (**)
50230003	Air strainer element

More extensive parts list on the internet: [WHISPERPOWER.EU](http://WHISPERPOWER.EU) (fast moving parts)

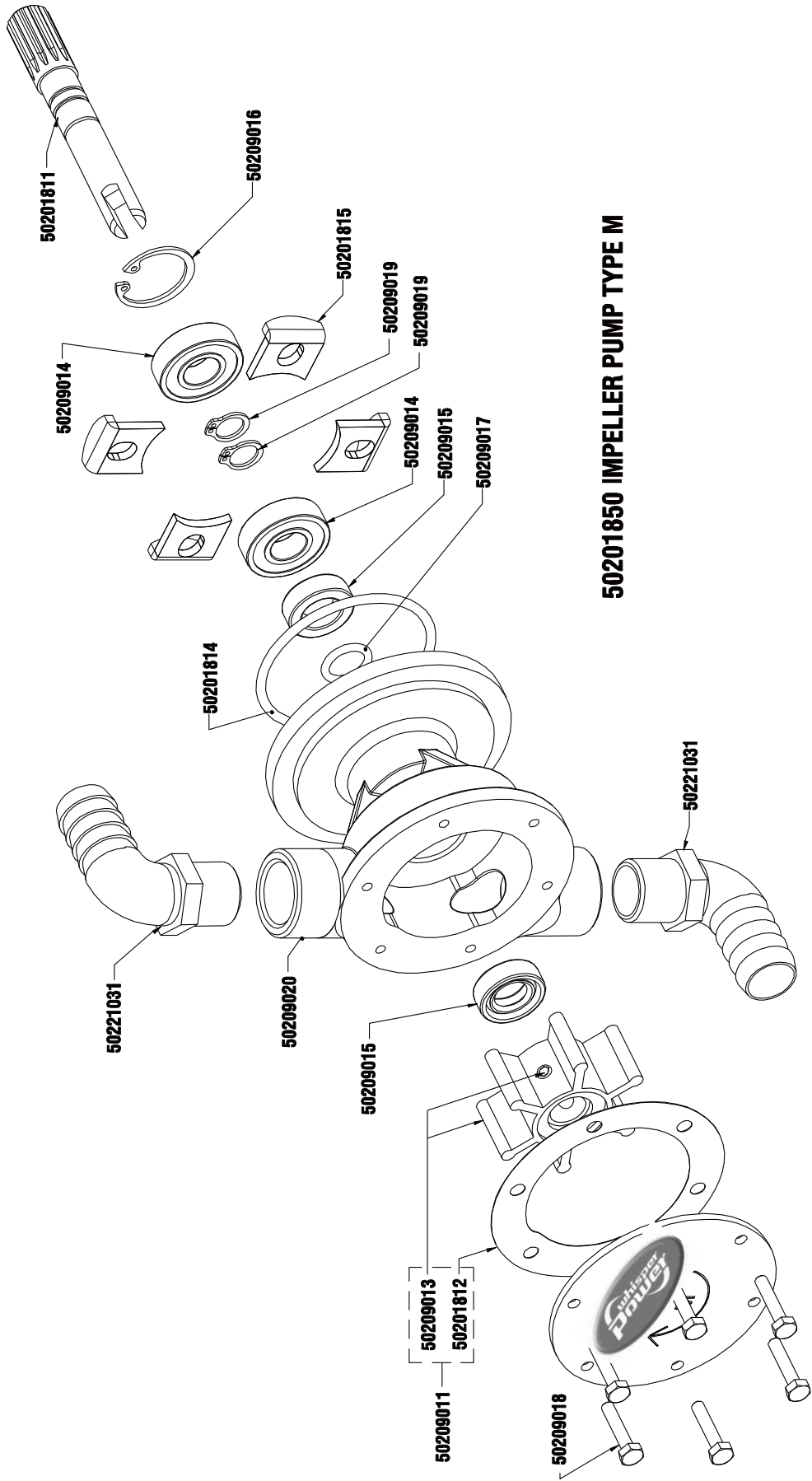

**50201850 IMPELLER PUMP TYPE M**

Fig 31: Water pump type M



# MAINTENANCE LOG

first service after 50 hours:                      hour counter:                      remarks

---

next service (every 150 hours)                      hour counter:

---

---

---

---

---

---

---

---

---

---

---

---

---

---

---

---

---

---

---

---





Kelvinlaan 82, 9207 JB Drachten, The Netherlands  
Tel : + 31-512-571550 / Fax : + 31-512-571599  
[www.whisperpower.eu](http://www.whisperpower.eu) / [info@whisperpower.nl](mailto:info@whisperpower.nl)