

## 5300 Series MPEG-2 HD/SD MediaPort: MIP-5301, MIP-5302, and MDM-5301

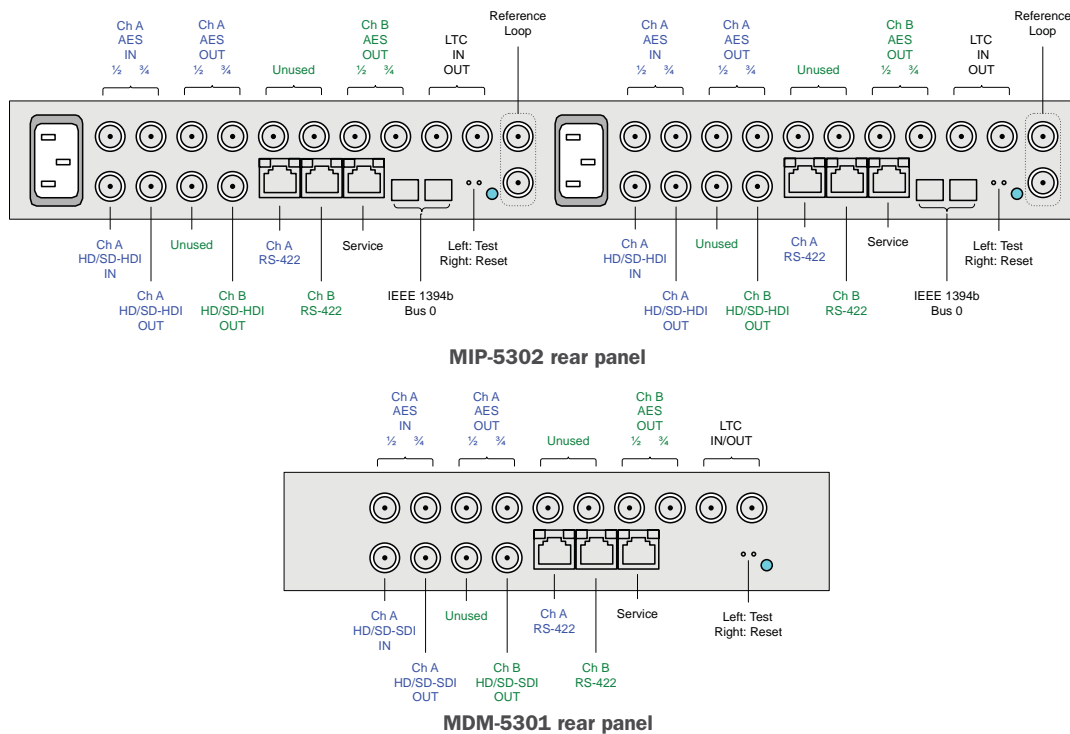

The Omneon 5300 series MPEG-2 HD/SD MediaPorts provide record and play of HD and SD video and digital audio, compressing it for storage on the Omneon Spectrum Video Server and the Omneon MediaDeck. The MIP-5301 and MIP-5302 are supplied in their own enclosure and connect to the server by external cabling. The MDM-5301 plugs directly into one of the two accessory slots of the MediaDeck, which supplies power, reference, and data via the backplane connector.

These MediaPorts offer the features described below. Unless otherwise specified, each feature applies to all models in the 5300 Series.

- One (MIP-5301 and MDM-5301) or two (MIP-5302) SDI video input/output channels, plus one (MIP-5301 and MDM-5301) or two (MIP-5302) SDI video output channels. Each channel is independently configurable for HD or SD operation, and complies with SMPTE 292M (HD SDI) and SMPTE 259M (SD SDI) as appropriate to the operating mode.
- Support for up to 16 channels of embedded audio, or up to 4 channels of discrete (AES/EBU) audio, per video channel
- Modules are 'hot swappable' and can be replaced without disrupting other operations on the server
- Video data compressed according to the following:
  - HD: MPEG-2 Long GOP method at 18-85 Mb/s, or MPEG-2 I-frame method (selectable) at 50-100 Mb/s
  - SD: MPEG-2 Long GOP method at 8-24.9 Mb/s, MPEG-2 Long GOP at 3-24.9 Mb/s (playback), MPEG-2 I-frame method at 25-50 Mb/s, or IMX 30, 40, or 50. Playback only is available for MPEG-2 Long GOP material at 3-8 Mb/s.
- HD frame geometry of 1920x1080i @ 25 and 29.97 Hz, and 1280x720p @ 50 and 59.94 Hz (MPEG-2 MP@HL and 422P@HL), and SD frame geometry of 720x480i @ 29.97 and 720x576i@25.
- Selectable horizontal sample rate of 1920 or 1440 at 1080i. Fixed horizontal sample rate of 1280 at 720p. (Note that horizontal sample rate is independent of picture width for 1080i; a 1920-pixel-wide picture can be sampled at 1440 if desired).
- 4:2:0 or 4:2:2 chroma sampling selectable at any bitrate.
- User-selectable MXF OP1a (self-contained essence), MXF OP1b, or QuickTime wrapper format
- Supports SDI embedded audio compliant with SMPTE 272M
- Supports pass-through (data mode) of pre-compressed audio such as AC-3 and Dolby™ E

Audio is supplied to the MediaPort by either the rear panel AES/EBU BNC connectors for up to 2 pairs (4 channels) per video channel, or by SDI embedded audio (16 audio channels per video channel). SDI embedded audio support in accordance with SMPTE 272M is a standard feature of the 5300 series, eliminating the need for external embedders and de-embedders.

## ■ PRODUCT SPECIFICATION

### 5300 Series MPEG-2 HD MediaPort Specifications

Parameter	Specification	Detail
Video	SMPTE 292M (HD) SMPTE 259M (SD) ITU-R BT.601 (data and electrical)	75 Ohm BNC 5301: 1 HD/SD SDI input/output plus 1 HD/SD SDI output 5302: 2 HD/SD SDI input/outputs plus 2 HD/SD SDI outputs
Audio	AES/EBU, 24 bits per sample @ 48 Khz  Pre-Compressed Audio	4 channels (2 AES pairs), or embedded per SMPTE 272M AC. 75 Ohm BNC connector Audio samples stored as uncompressed PCM  Pass-through (data mode) of AC-3 and Dolby E
HD video compression	MPEG-2 Long GOP 18-85 Mb/s MPEG-2 I-frame 50-100 Mb/s 4:2:0 or 4:2:2 chroma selectable at any bitrate	MPEG-2 MP@HL, 422P@HL
HD Video formats	1920 x 1080i @ 25 and 29.97 fps 1440 x 1080i @ 25 and 29.97 fps  1280 x 720p @ 50 and 59.94 fps	Full raster horizontal sampling ¾ - raster horizontal sampling  Progressive scan
SD video compression	MPEG-2 Long GOP 8-24.9 Mb/s (record) MPEG-2 Long GOP 3-24.9 Mb/s (play) MPEG-2 I-frame 25-50 Mb/s IMX 30, 40, 50 4:2:0 or 4:2:2 chroma selectable at any bitrate	MPEG-2 MP@ML, 422P@ML
SD Video formats	720 x 480i @ 29.97 fps 720 x 576i @ 25 fps	Interlaced 525-line frames delivered in 2 fields Interlaced 625-line frames delivered in 2 fields
Control	VDCP and limited BVW protocol Omneon Player API	RS-422 interface; RJ-45 connector, RJ-45 to DB-9 adapter supplied Control of 5300 series via software; access via Ethernet to server
Server interface	IEEE 1394b	MIP-530x: Interface via external cable to MediaDirector MDM-5301: Interface by backplane connection to MediaDeck
Ancillary data	SMPTE 328M SMPTE 334 and EIA-708	Timecode, Dolby metadata, Japanese subtitle, user-defined HD-SDI closed caption
Timecode	LTC SMPTE 328M	75-ohm BNC connector Supplied in MPEG user data
Reference timing signal	Analog composite video with color burst, black	MIP-530x: Supplied via REF LOOP connector MDM-5301: Supplied by MediaDeck; sourced from MediaDeck's REF LOOP connector
Environmental	Operating Temperature Humidity	+10C to +35C 10% to 80% non-condensing
Safety	USL/CNL	UL 670950-1, 1st Edition CSA C22.2 No. 60950-1-03, 1st Edition IEC 60950-1 (2001) 1st Edition
EMC	FCC Part 15, ICES-003 ICES-003 Directive of Electromagnetic Compatibility (89/336/EEC) including amendments CISPR 22	Class A for Digital Equipment, USA Class A for Digital Equipment, Canada EN55022:1998, EN55024:1998 Emissions from Information Technology Equipment Immunity for Information Technology Equipment Class A
Dimensions	MIP-530x: W: 44.4 cm (17.5 inches) H: 4.4 cm (1.75 inches) D: 64.6 cm (25.43 inches) 65.4 cm (25.75 inches) 66.5 cm (26.18 inches) MDM-5301: plugs into MediaDeck accessory slot	Chassis only, inside rack 1 RU Chassis front to chassis rear Chassis front to rear of BNC connectors Front of bezel to rear of BNC connectors Front bezel extends forward [Max. 1.1 cm (0.4375 inches)] from chassis front edge and rack ear plane.
Weight	MIP-5301: 5.4 kg (12.0 lb) MIP-5302: 6.4 kg (14.2 lb) MDM-5301:	
Power	MIP-530x: 100-240V AC 45-63 Hz 120 W	MIP-530x: Dual redundant power supplies with separate IEC 60320 C-14 sockets. MDM-5301: Power supplied from MediaDeck.



[www.omneon.com](http://www.omneon.com)

**U.S. Headquarters:**  
965 Stewart Drive  
Sunnyvale, CA 94085  
ph +1 866.861.5690  
ph +1 408.585.5000  
fx +1 408.585.5099

**Europe:**  
5 Lindenwood  
Chineham, Basingstoke  
RG24 8QY United Kingdom  
ph +44 1256.347.400  
fx +44 1256.347.410

**Japan:**  
Ginza 3-Chome Bldg. 8F  
3-14-1 Ginza, Chuo-ku  
Tokyo 104-0061 Japan  
ph +81 03.5565.6735  
fx +81 03.5565.6736

**Asia/Pacific:**  
20 Loyang Crescent  
Singapore 508984  
ph +65 6548.0500  
fx +65 6548.0504

©2008 Omneon Inc. All rights reserved. Omneon and the Omneon logo are registered trademarks of Omneon, Inc. All other trademarks are the property of the respective companies. Printed in USA | June 2008. The information contained in this document is subject to change without notice or obligation. SP\_MediaPort5300\_080623