



# Avenger Stands

## A625B AVENGER

### MIDI KIT STAND

⌄ 27in	🔒 2.4lbs
⌄ 94in	⬇️ 9lbs
📏 26in	📏 5/8in
⚙️ 37in	

4 sections, 3 risers.  
 : 25, 22, 19, 16,mm.  
 Leg : 19mm.

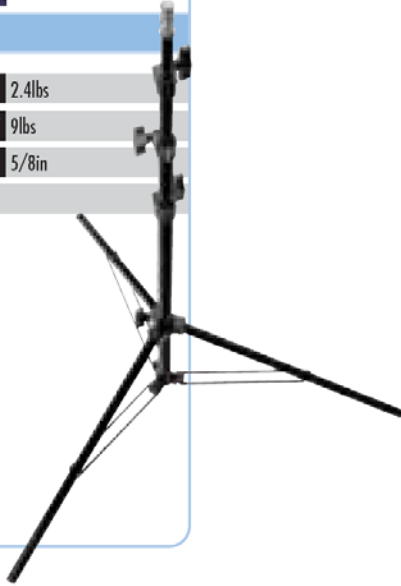

## A630B AVENGER

### MIDI-MAX KIT STAND

⌄ 35.8in	🔒 4.8lbs
⌄ 129.9in	⬇️ 19.8lbs
📏 35.4in	⚡ 4lbs @ 129.9in
⚙️ 37.8in	👤 Type 21
	🔌 110

Black aluminum stand.  
 4 sections, 3 risers.  
 Ø: 35, 30, 25, 20mm.  
 Leg Ø: 22mm.  
 This stand features captive lock-off T-knobs,  
 high efficiency, brake shoe locking risers and  
 anodized black coating.

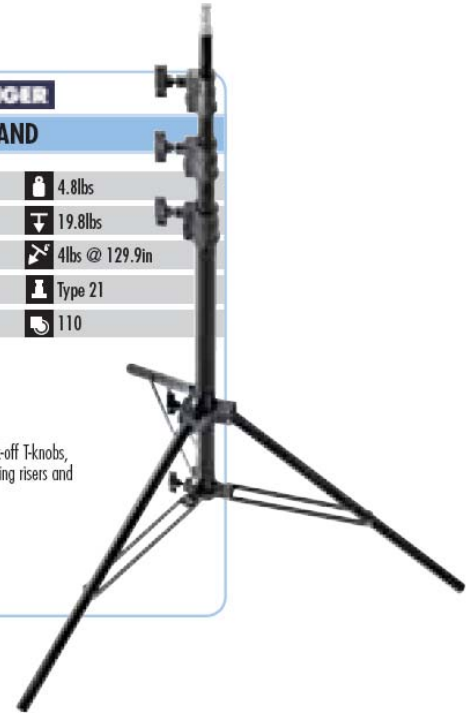

## A635B AVENGER

### MAXI KIT STAND

⌄ 42.9in	🔒 5.5lbs
⌄ 151.6in	⬇️ 19.8lbs
📏 42.1in	⚡ 2lbs @ 151.6in
⚙️ 42.9in	👤 Type 21
	🔌 110

Black aluminum stand.  
 4 sections, 3 risers.  
 Ø: 35, 30, 25, 20mm.  
 Leg Ø: 22mm.



## A645B AVENGER

### ALU-CINE COMBO STAND

⌄ 490.2in	🔒 6.6lbs
⌄ 124in	⬇️ 26.4lbs
📏 48in	⚡ 9.9lbs @ 124in
⚙️ 46.5in	👤 Type 34
	🔌 110

Aluminum legs with aluminum risers.  
 3 sections, 2 risers.  
 Ø: 35, 30, 25mm.  
 Leg Ø: 22mm.  
 1 leveling leg.

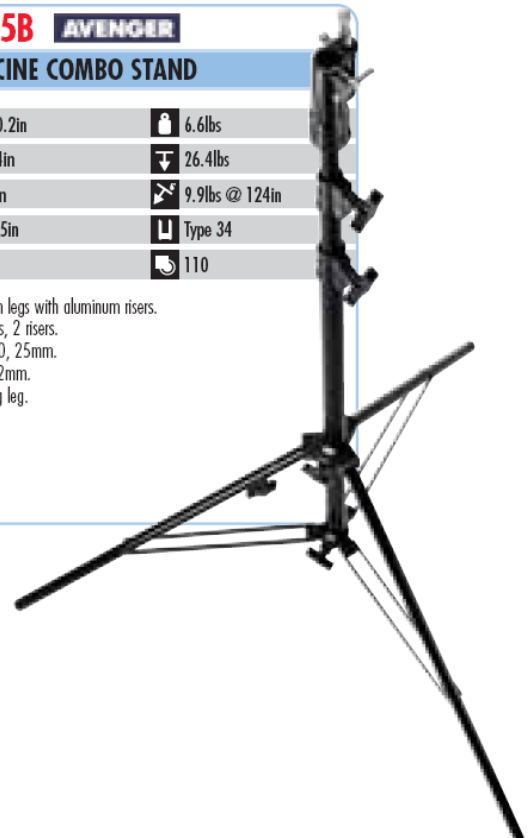



# Avenger Stands

## A650 AVENGER CINE COMBO STAND

⚙️ 46.5in	🔒 16.5lbs
📏 86.6in	⬇️ 66lbs
📏 45.7in	📏 15.4lbs @ 86.6in
📏 46.5in	📏 Type 34
🔄	🔌 110

Chrome steel stand.  
2 sections, 1 riser.  
Ø: 35, 30mm.  
Leg Ø: 22mm.  
1 leveling leg.

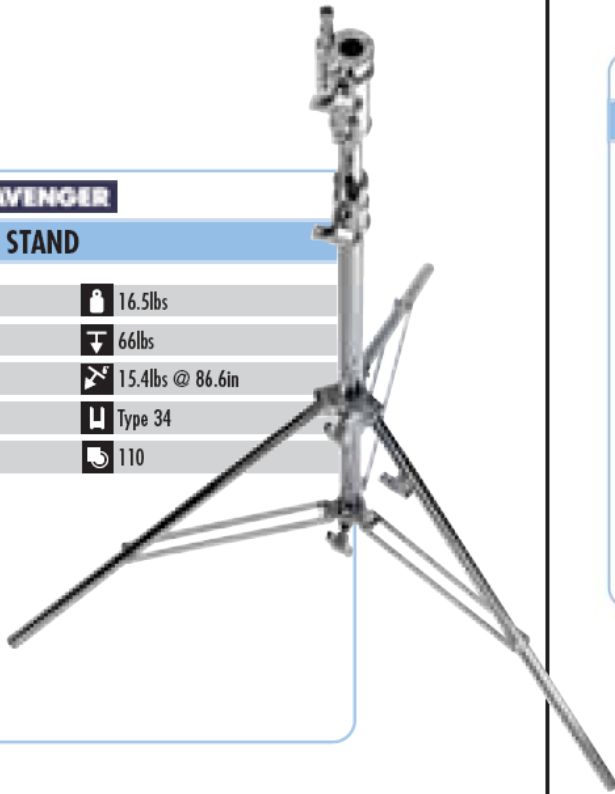

## A122 AVENGER MINI LOW COMBO STAND

⚙️ 37in	🔒 13lbs
📏 55.5in	⬇️ 66lbs
📏 32.7in	📏 22lbs @ 55.5in
📏 31.5in	📏 Type 34
🔄	🔌 A9000

Legs and column in steel.  
Riser in aluminum.  
2 sections, 1 riser.  
Ø: 45, 40mm.  
Leg: 25x25mm.  
1 leveling leg.

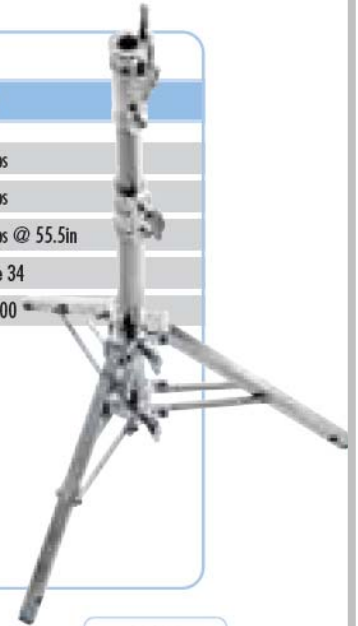

Universal top fitting type 34-1  
1/2" socket plus rubber 5/8" socket or pop-up 5/8" stud.

## A105B AVENGER BLACK ALU-COMBO STAND

⚙️ 65.7in	⬇️ 66lbs
📏 160.6in	📏 5.5lbs @ 160.6in
📏 56.3in	📏 Type 34
📏 53.1in	🔌 A9000
🔒 15.2lbs	

Aluminum legs with aluminum risers.  
4 sections, 3 risers.  
Ø: 45, 40, 35, 30mm.  
Leg: 25x25mm.  
1 leveling leg.



## A115B AVENGER BLACK ALU-COMBO STAND

⚙️ 62.2in	⬇️ 66lbs
📏 128in	📏 15.4lbs @ 128in
📏 52.8in	📏 Type 34
📏 53.1in	🔌 A9000
🔒 13.6lbs	

Aluminum legs with aluminum risers.  
3 sections, 2 risers.  
Ø: 45, 40, 35mm.  
Leg: 25x25mm.  
1 leveling leg.



## A105 AVENGER SILVER ALU-COMBO STAND

🔒 15.6lbs	📏 13.2lbs @ 160.6in
⬇️ 66lbs	🔌 A9000

Steel legs with aluminum risers.

## A115 AVENGER SILVER ALU-COMBO STAND

🔒 13.6lbs	📏 15.4lbs @ 128in
⬇️ 66lbs	🔌 A9000

Steel legs with aluminum risers.



# Avenger Stands

## A120 AVENGER

### LOW COMBO STAND

39.8in	17.2lbs
78in	77lbs
36.6in	6.6lbs @ 78in
31.5in	Type 34
	A9000

Chrome steel stand.  
3 sections, 2 risers.  
Ø: 45, 40, 35mm.  
Leg: 25x25mm.  
1 leveling leg.

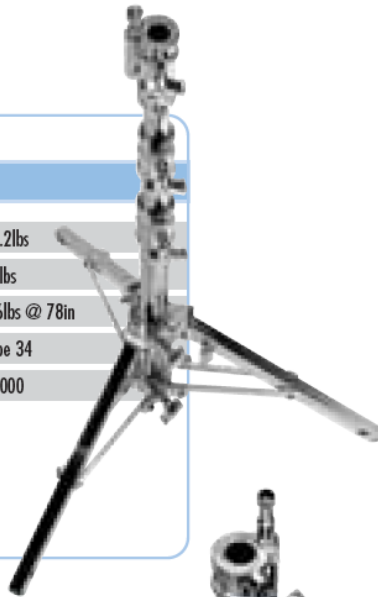

## A110 AVENGER

### COMBO STAND

62.2in	88lbs
128in	33lbs @ 128in
52.8in	Type 34
53.1in	A9000
24.2lbs	

Chrome steel stand.  
3 sections, 2 risers.  
Ø: 45, 40, 35mm.  
Leg: 25x25mm.  
1 leveling leg.

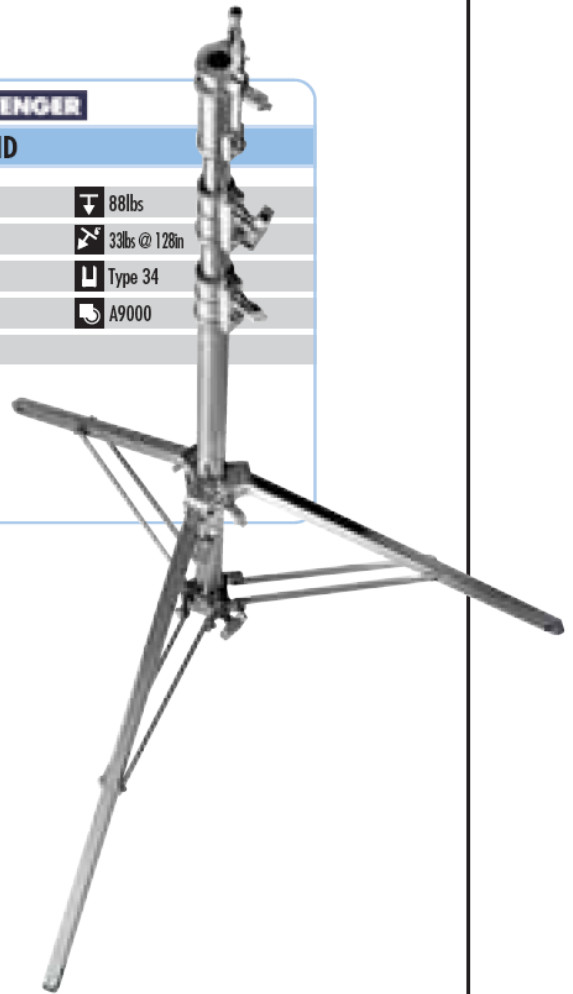

## A100 AVENGER

### HIGH COMBO STAND

65.7in	88lbs
160.6in	15.4lbs @ 160.6in
56.3in	Type 34
53.1in	A9000
26.8lbs	

Chrome steel stand.  
4 sections, 3 risers.  
Ø: 45, 40, 35, 30mm.  
Leg: 25x25mm.  
1 leveling leg.



## A9000 AVENGER

### BRAKED WHEEL

7.3lbs

Ø: 125mm for 25x25mm square legs.  
Set of three.





# Avenger Stands

## STANDARD BASE

### STANDARD BASE

- The Avenger Century stand is unlike any other. Fitted with captive handles that do not vibrate free; utilizing a new lightweight steel making them up to 2.2lbs lighter but just as strong; triple chrome plating resistant to corrosion; collar castings that protect fingers; field serviceable parts; all these features make this stand the best on the market.
- Century Stands have thousands of uses. Coupled with a Grip Head (D200) and a Grip Arm (D520/D500), the stand can be used to boom lights, hold backgrounds, support reflectors, microphones, foam board, scrims, flags, etc.
- 20", 30", 40" and 60" stands - heights up to 190" with loads up to 22lbs.
- Fold away, spring loaded legs with unique mounts which are field serviceable and easy to replace.
- Deep inset plastic feet that do not come off in use.
- High quality finish resists all weather conditions.
- Detachable base stand - also available as turtle base only.
- Captive "T" handles.



The innovative design on the Century stand base allows individual legs to be set at any angle, and can be positioned in locations not possible for classic stands.



Important! Counterweight sandbags must always be used on the legs to ensure safe, stable operation even at full height extension.

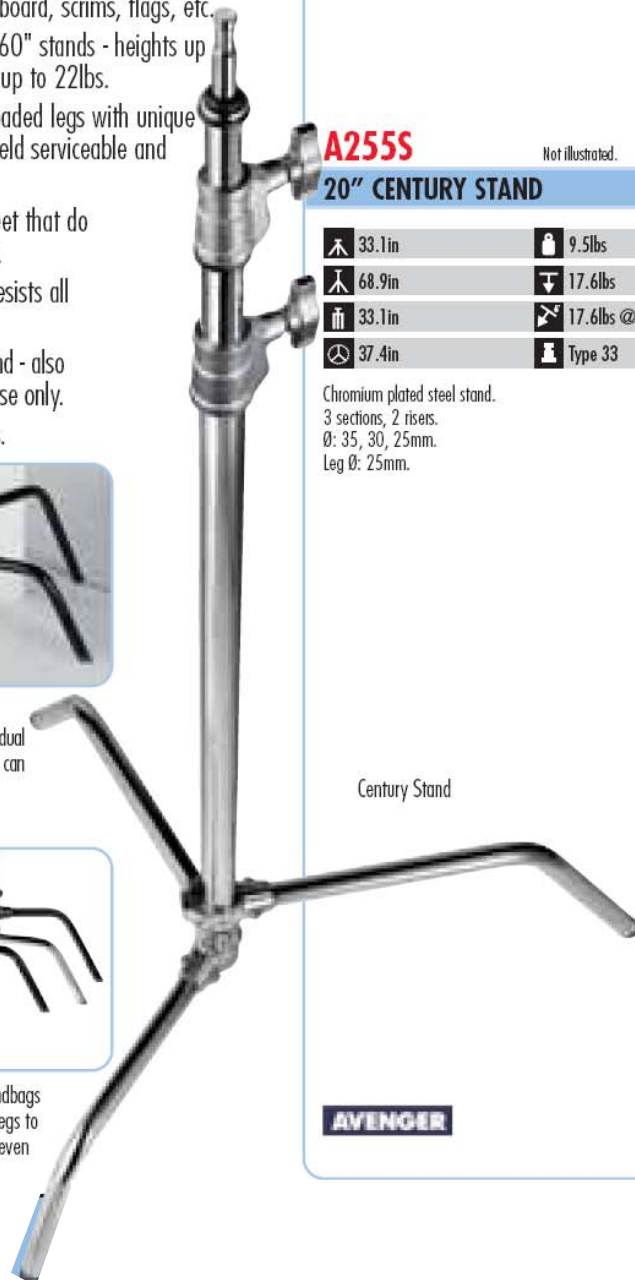

Century Stand

### A280S

CB

#### 20" MINI BASE CENTURY STAND

⚙️ 33.1in	🔒 8.8lbs
⚙️ 68.9in	⬇️ 15.4lbs
📏 33.1in	⚡ 2.2lbs @ 68.9in
⚙️ 29.5in	👤 Type 33

Chromium plated steel stand.  
3 sections, 2 risers.  
Ø: 35, 30, 25mm.  
Leg Ø: 25mm.

### A235S

Not illustrated.

#### 30" CENTURY STAND

⚙️ 43.3in	🔒 10.6lbs
⚙️ 99.6in	⬇️ 22lbs
📏 43.3in	⚡ 4.4lbs @ 99.6in
⚙️ 37.4in	👤 Type 33

Chromium plated steel stand.  
3 sections, 2 risers.  
Ø: 35, 30, 25mm.  
Leg Ø: 25mm.

**SPECIAL ORDER.**  
**ALLOW 10 WEEKS DELIVERY TIME**

### A255S

Not illustrated.

CB

#### 20" CENTURY STAND

⚙️ 33.1in	🔒 9.5lbs
⚙️ 68.9in	⬇️ 17.6lbs
📏 33.1in	⚡ 17.6lbs @ 68.9in
⚙️ 37.4in	👤 Type 33

Chromium plated steel stand.  
3 sections, 2 risers.  
Ø: 35, 30, 25mm.  
Leg Ø: 25mm.

### A205S

Not illustrated.

CB

#### 40" CENTURY STAND

⚙️ 52.8in	🔒 12.1lbs
⚙️ 129.1in	⬇️ 22lbs
📏 52.8in	⚡ 1.1lbs @ 129.1in
⚙️ 37.4in	👤 Type 33

Chromium plated steel stand.  
3 sections, 2 risers.  
Ø: 35, 30, 25mm.  
Leg Ø: 25mm.

### A208S

Not illustrated.

CB

#### 60" CENTURY STAND

⚙️ 72.8in	🔒 15lbs
⚙️ 189.8in	⬇️ 22lbs
📏 72.8in	👤 Type 33
⚙️ 37.4in	

Chromium plated steel stand.  
3 sections, 2 risers.  
Ø: 35, 30, 25mm.  
Leg Ø: 25mm.





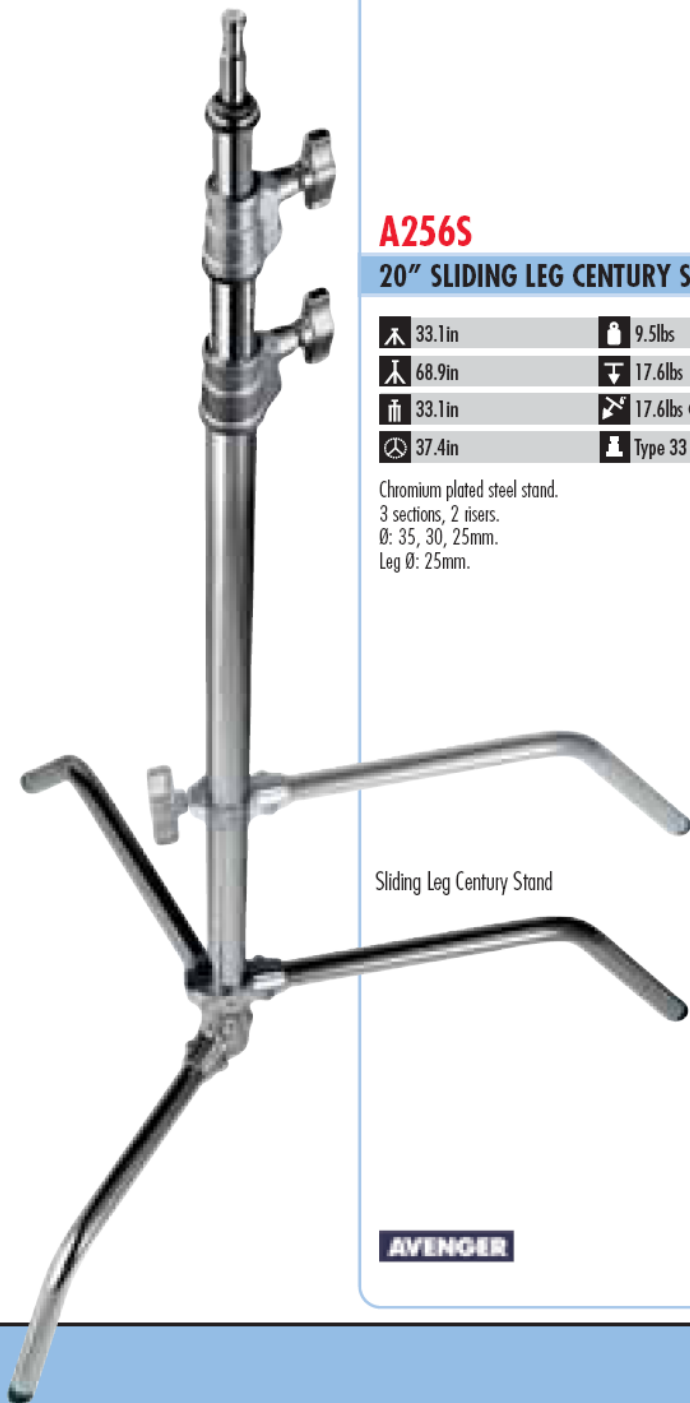



**AVENGER**

## SLIDING BASE



### A256S

#### 20" SLIDING LEG CENTURY STAND

	33.1in		9.5lbs
	68.9in		17.6lbs
	33.1in		17.6lbs @ 68.9in
	37.4in		Type 33

Chromium plated steel stand.  
3 sections, 2 risers.  
Ø: 35, 30, 25mm.  
Leg Ø: 25mm.









Sliding Leg Century Stand

**AVENGER**

### A245S

Not illustrated.

#### 30" SLIDING LEG CENTURY STAND

	43.3in		10.6lbs
	99.6in		22lbs
	43.3in		4.4lbs @ 99.6in
	37.4in		Type 33









Chromium plated steel stand.  
3 sections, 2 risers.  
Ø: 35, 30, 25mm.  
Leg Ø: 25mm.

**SPECIAL ORDER.**  
**ALLOW 10 WEEKS DELIVERY TIME**

### A215S

Not illustrated.

#### 40" SLIDING LEG CENTURY STAND







	52.8in		12.1lbs
	129.1in		22lbs
	52.8in		1.1lbs @ 129.1in
	37.4in		Type 33

Chromium plated steel stand.  
3 sections, 2 risers.  
Ø: 35, 30, 25mm.  
Leg Ø: 25mm.

### A218S

Not illustrated.

#### 60" SLIDING LEG CENTURY STAND

	72.8in		15lbs
	189.8in		22lbs
	72.8in		Type 33
	37.4in		

Chromium plated steel stand.  
3 sections, 2 risers.  
Ø: 35, 30, 25mm.  
Leg Ø: 25mm.



# Avenger Stands

## DETATCHABLE BASE

### A290S



#### 20" MINI DETACHABLE CENTURY STAND BASE

33.1in	15.4lbs
61in	2.2lbs @ 61in
33.1in	Type 33 + type 35
29.5in	1 1/8in
11.4lbs	

Chromium plated steel stand.  
3 sections, 2 risers.  
Ø: 35, 30, 25mm.  
Leg Ø: 25mm.

### A257S

Not illustrated.



#### 20" DETACHABLE CENTURY STAND BASE

33.1in	22lbs
61in	17.6lbs @ 61in
33.1in	Type 33 + type 35
29.5in	1 1/8in
12.3lbs	

Chromium plated steel stand.  
3 sections, 2 risers.  
Ø: 35, 30, 25mm.  
Leg Ø: 25mm.

### A225S

Not illustrated.



#### 40" DETACHABLE CENTURY STAND BASE

52.8in	22lbs
118.1in	1.1lbs @ 118.1in
52.8in	Type 33 + type 35
37.4in	1 1/8in
13.6lbs	

Chromium plated steel stand.  
3 sections, 2 risers.  
Ø: 35, 30, 25mm.  
Leg Ø: 25mm.

### A228S

Not illustrated.



#### 60" DETACHABLE CENTURY STAND BASE

72.8in	16.6lbs
178.7in	22lbs
72.8in	Type 33 + type 35
37.4in	1 1/8in

Chromium plated steel stand.  
3 sections, 2 risers.  
Ø: 35, 30, 25mm.  
Leg Ø: 25mm.



AVENGER



# Avenger Stands

## CENTURY STAND ACCESSORIES

**A275S**

**CB**

### 20" DOUBLE RISER COLUMN

26.8in	4.8lbs
54.7in	Type 33 + type 35

3 sections (Ø: 35, 30, 25mm) chrome steel column.

**A270S**

Not illustrated.

**CB**

### 40" DOUBLE RISER COLUMN

46.5in	7.3lbs
112.2in	Type 33 + type 35

3 sections (Ø: 35, 30, 25mm) chrome steel column.

**A278S**

Not illustrated.

**CB**

### 60" DOUBLE RISER COLUMN

66.5in	9.9lbs
172.4in	Type 33 + type 35

3 sections (Ø: 35, 30, 25mm) chrome steel column.



- Turtle Base Century stands offer the most features allowing you to use the base separately as a backlight stand or inserting various sized columns to meet your needs.

**A268**

Not illustrated.

**CB**

### MINI TURTLE BASE

10.6in	5.9lbs
29.5in	1 1/8in

**A265**

**CB**

### TURTLE BASE

10.6in	6.6lbs
37.4in	1 1/8in



**AVENGER**

**AVENGER**



# Avenger Stands

## B200 AVENGER

### WIND-UP STAND WITH BRAKED WHEELS

📏 71.3in	📊 52.8lbs
📏 153.5in	📊 66lbs
📏 79.1in	📊 19.8lbs @ 153.5in
📏 55.9in	📊 Type 14

Chrome steel stand.  
3 sections, 2 risers.  
Ø: 55, 45, 38mm.  
Leg Ø: 30mm.  
1 leveling leg.

SPECIAL ORDER.  
ALLOW 10 WEEKS  
DELIVERY TIME



## B250X AVENGER

### SUPER WIND-UP STAINLESS STEEL STAND WITH BRAKED WHEELS

📏 67.7in	📊 85.8lbs
📏 159in	📊 176lbs
📏 77.2in	📊 143lbs @ 152in
📏 70.9in	📊 1 1/8in

Same as 307XJ but complete with braked wheels.







# Avenger Stands

## B130 AVENGER

Not illustrated.

### 3 SECTION STRATO SAFE STAND WITH BRAKED WHEELS

154cm	52kg
338cm	80kg
192cm	80kg@338cm
213cm	1 1/8in

Chrome steel stand complete with braked wheels.  
 3 sections, 2 risers.  
 Ø: 90, 80, 70mm.  
 Leg: 35x35mm.  
 Includes Wind Brace Kit code **B9000W**.



SPECIAL ORDER. ALLOW 10 WEEKS DELIVERY TIME

## B140 AVENGER

Not illustrated.

### 4 SECTION STRATO SAFE STAND WITH BRAKED WHEELS

172cm	62kg
467cm	70kg
209cm	70kg@467cm
213cm	1 1/8in

Chrome steel stand complete with braked wheels.  
 4 sections, 3 risers.  
 Ø: 90, 80, 70, 60mm.  
 Leg: 35x35mm.  
 Includes Wind Brace Kit code **B9000W**.



SPECIAL ORDER. ALLOW 10 WEEKS DELIVERY TIME

## B150 AVENGER

Not illustrated.

### 5 SECTION STRATO SAFE STAND WITH BRAKED WHEELS

190cm	71kg
610cm	70kg
225cm	70kg@610cm
213cm	1 1/8in

Chrome steel stand complete with braked wheels.  
 5 sections, 4 risers.  
 Ø: 90, 80, 70, 60, 50mm.  
 Leg: 35x35mm.  
 Includes Wind Brace Kit code **B9000W**.

## B150PS AVENGER

### 5 SECTION STRATO SAFE STAND WITH PNEUMATIC WHEELS

Same as B150 but with pneumatic wheels.

