



# **AEQ BRAVO**

**Broadcast Mixing Console**

**USER'S MANUAL**

**ED. 12/07**

V. 1.5 - 20/05/2008

## CONTENTS

1. INTRODUCTION.....	3
1.1. General.....	3
1.2. Maintenance.....	3
1.3. Warranty.....	4
2. EQUIPMENT POWER SUPPLY.....	5
2.1. General.....	5
2.2. Switching on the equipment.....	5
3. AUDIO CONNECTIONS.....	6
3.1. General.....	6
3.2. General diagram.....	7
4. FUNCTIONAL DESCRIPTION.....	8
4.1. Mono Mic./Line channels.....	8
4.2. Stereo double line channels.....	10
4.3. Monitoring and control area.....	12
4.3.1. PROGRAM output.....	13
4.3.2. AUDITION output.....	13
4.3.3. RECORDING outputs.....	13
4.3.4. Control room monitoring.....	14
4.3.5. Studio room monitoring.....	15
4.3.6. "AIR" or "EXTERNAL" input.....	15
4.3.7. Internal telephone hybrids or four-wire interface for external hybrids.....	16
4.3.7.1. Adjusting the internal hybrids.....	17
4.3.8. Talkback ("T'BACK") circuit.....	18
4.3.9. Studio monitors muting.....	18
4.3.10. Studio signaling circuit.....	18
4.3.11. Remote control of external equipments.....	18
4.4. VU-meters panel.....	19
5. INTERNAL PROGRAMMING AND CONNECTION DIAGRAMS.....	20
5.1. Programming and internal adjustments.....	20
5.2. Audio connection.....	21
5.3. External hybrids connection.....	22
5.4. Signaling connection.....	22
6. TECHNICAL SPECIFICATIONS.....	23
6.1. Mono Mic./Line inputs.....	23
6.2. Stereo Line inputs.....	23
6.3. Program output.....	23
6.4. Recording outputs.....	23
6.5. Signaling.....	23
6.6. Power supply.....	23
6.7. Dimensions and weight.....	24
6.7.1. Dimensions.....	24
6.7.2. Weight.....	24

## 1. INTRODUCTION.

### 1.1. General.

The following security and precautionary measures must be observed during all phases of operation and maintenance of the unit. Failure to comply with the instructions highlighted in this manual could affect the performance and function of the equipment.

**AEQ accept no responsibility for damage or injury caused by incorrect use or manipulation of the equipment.**

- **Read all the instructions:** To obtain the optimum performance and reliability from the moment of installation, and to prevent injury, incorrect operation or damage to the equipment, it is absolutely indispensable to thoroughly read all the instructions contained in this manual **before connecting and operating the equipment.**
- **Protection against water and humidity:** This equipment is not recommended for use in areas affected by rain water etc., or sites with damp floors, or in places which are subject to a high degree of atmospheric humidity which is liable to condense in the equipment.
- **Ventilation, fire and inflammable vapours: AEQ BRAVO** must not be placed close to a source of heat. The use of electrical or electronic equipment near a source of fire or in an atmosphere containing inflammable vapors is extremely dangerous and must be avoided at all costs. All the ventilation grilles must remain unobstructed to permit sufficient ventilation and allow the dissipation of heat to the exterior of the equipment.

### 1.2. Maintenance.

Maintenance operations on this unit should only be carried out by qualified technical personnel. **AEQ** does not accept responsibility for any damage or injury to the equipment caused by maintenance by unauthorised persons, nor for any damage or injury to other equipment or persons caused by any unauthorised repair or maintenance operation.

**CAUTION.** A risk of severe electrical shock exists due to very high voltages which are present in the power supply unit. Therefore proceed with absolute caution when opening up this unit.

The **AEQ BRAVO** mixing console does not require preliminary adjustment. After programming has been carried-out, as described in this manual either by the user or the manufacturer, no additional operations whatsoever are necessary to obtain optimum performance.

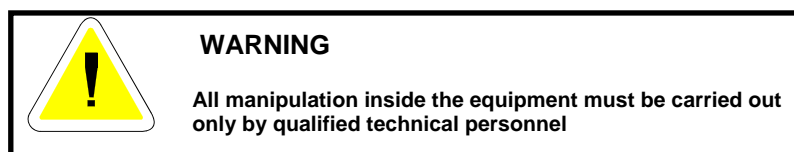

### 1.3. Warranty.

AEQ guarantees that this product has been designed and manufactured under a certified Quality Assurance System and according to the ISO 9001/2002 Standard. AEQ therefore guarantees that the necessary test protocols to assure the proper operation and the specified technical characteristics of the product have been followed and accomplished.

**This includes that the general protocols for design and production this product are conveniently documented.**

- 1.- The present guarantee does not exclude or limit in any way any legally recognized right of the client.
- 2.- The period of guarantee is defined to be twelve natural months starting from the date of purchase of the product by the first client.

To qualify for the guarantee, an authorized distributor must be notified of the problem within 30 days of the defect. Also, the warranty period must not have expired. To expedite the process always reference the invoice and serial number of the product when filing a complaint for defect.

All returns, for repair or replacement, must be expressly authorized by AEQ Technical Service.

AEQ reserves the right to refuse acceptance of any product that fails to meet the above criteria.

- 3.- AEQ will repair at its own cost the faulty product once returned, including the necessary labor to carry out such repair, whenever the failure is caused by defects of the materials, design or workmanship. The repair will be carried out at any of the AEQ authorized Technical Service Center. This guarantee does not include the freight charges of the product to or from such Authorized Technical Service Center.
- 4.- AEQ will not extend the guarantee for any product that has been repaired or substituted. The guarantee period begins from the time of original purchase only.
- 5.- The present guarantee will not be applicable in the following situations:  
improper use or contrary use of the product as per the User or Instruction Manual; violent manipulation; exhibition to humidity or extreme thermal or environmental conditions or sudden changes of such conditions; electrical discharges or lightning; oxidation; modifications or non-authorized connections; repairs or non-authorized disassembly of the product; spill of liquids or chemical products.
- 6.- Under no circumstances, whether based upon this Limited Guarantee or otherwise, shall AEQ, S.A. be liable for incidental, special, or consequential damages derived from the use or from the impossibility of using the product.

## 2. EQUIPMENT POWER SUPPLY.

### 2.1. General.

**Before connecting the equipment to electrical mains:** The **AEQ BRAVO** mixer power supply cable is supplied with European Standard and USA type mains interconnecting plugs. In certain countries it could be necessary to exchange this plug to adapt to the existing local standards. If this is the case, the substitution of the plug should be carried out before proceeding.

Equipment power supply is supplied through specific connector, using supplied cable. The equipment is designed to operate with alternating voltage between 110 and 240V at 50 or 60 Hz. The maximum consumption is approximately 100VA. Inside the power connector compartment, there are two 1.6 Amp. Slow Blow fuses, one of them used as a spare.

### 2.2. Switching on the equipment.

**AEQ BRAVO** is prepared for connection to the electrical mains. Prior to connection of the power cord, ensure that power supply switch **POWER** is in the off position.

Activate the power supply switch **POWER**. If all the previous instructions have been followed correctly, the "**POWER ON**" indicator will illuminate indicating that the equipment is receiving power.

### 3. AUDIO CONNECTIONS.

#### 3.1. General.

The connections of Audio of the Microphone inputs and the Program output (XLR connectors) is done according to standards recommended by **AES 14-1.992 (ANSIS 4.48 - I.992)**. This recommendation is based on **IEC 268 - 12 of 1.987 "Equipment for sound systems part 12, application of connectors for radio Broadcast and similar uses"**.

The Audio connection cables should be checked for compatibility with the standards indicated. If this is not the case they must be exchanged or modified since problems could be encountered with the phase of the Audio signal.

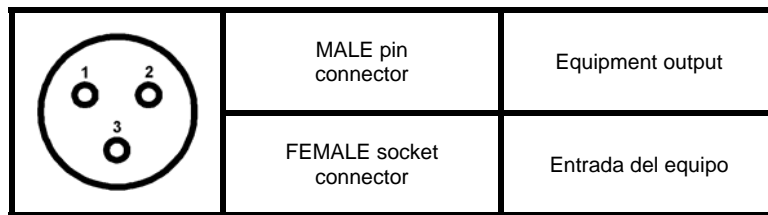

#### CONTACT

Application and Power Supply	1	2	3
Balanced Mono Channel	Screen	Positive polarity	Return
Unbalanced Mono Channel	Screen and return	Positive polarity	*
Balanced Mono Channel Phantom power	Screen and negative power	Positive polarity and power	Positive power return
Balanced Mono Channel Power A-B	Screen	Positive polarity and power	Negative power return

\* If a balanced microphone is connected to an unbalanced amplifier input, the input contact 3 is connected to contact 1.

**NOTE:** This equipment does **NOT** have a "Phantom" Microphone Power Supply.

### 3.2. General diagram.

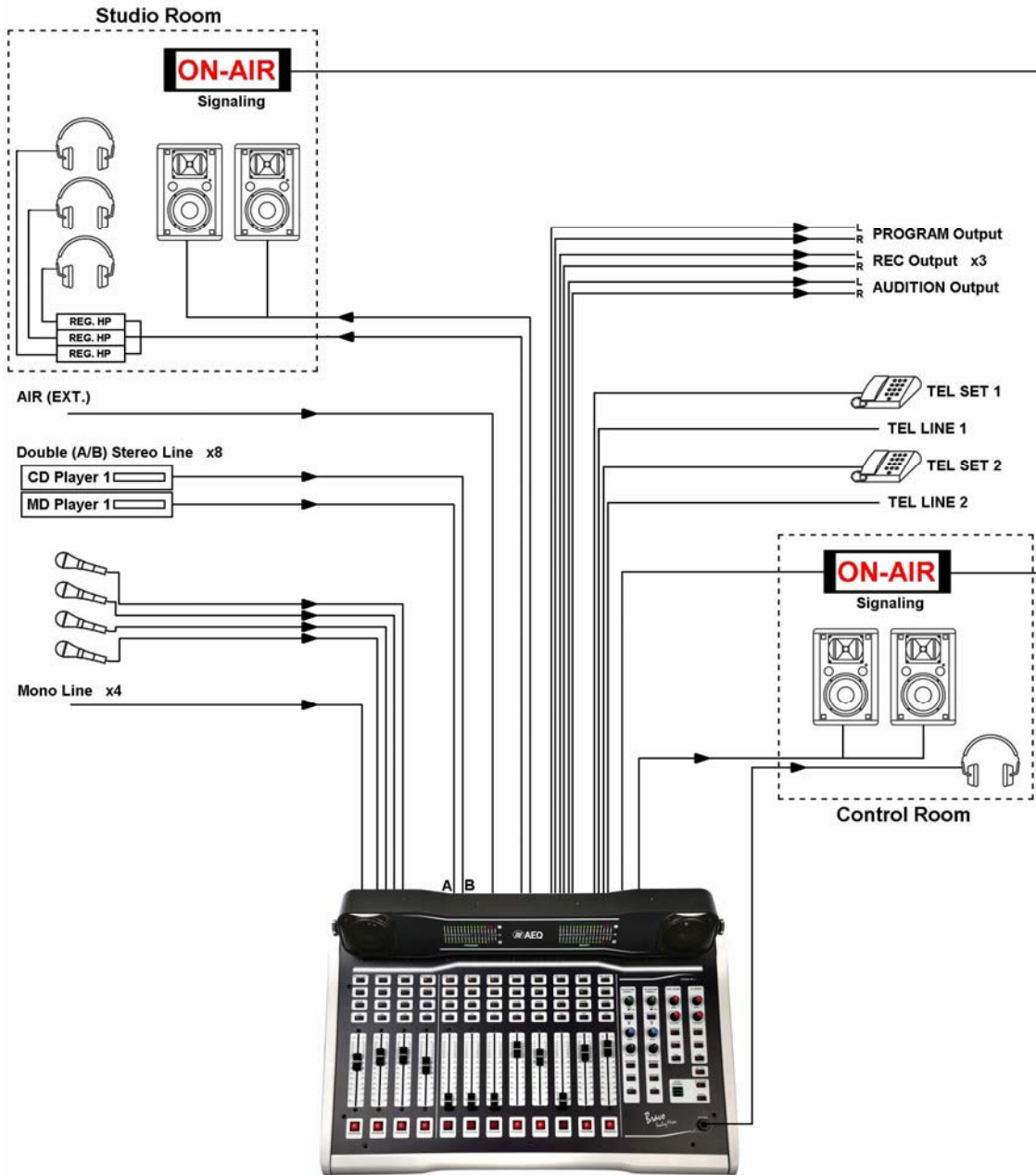

## 4. FUNCTIONAL DESCRIPTION.

### 4.1. Mono Mic./Line channels.

The **AEQ BRAVO** mixer has four independent Mic/Line inputs: four electronically balanced inputs at microphone level with Female XLR-3 connectors and four asymmetrical at line level with RCA connectors:

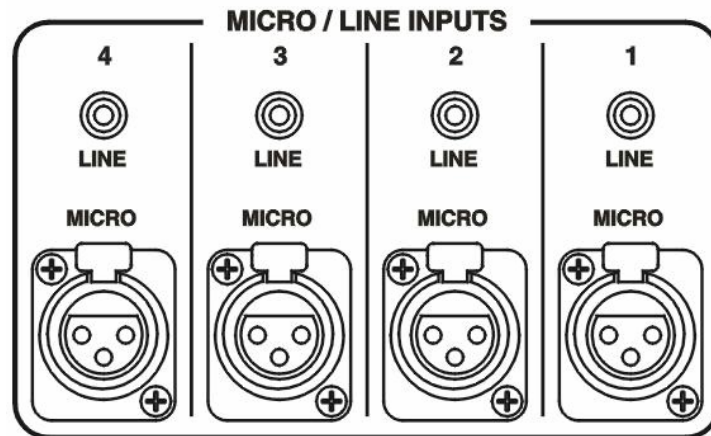

Each Mic./Line input has a fine adjustment for input gain. An specific tool is needed in order to make this adjustment:

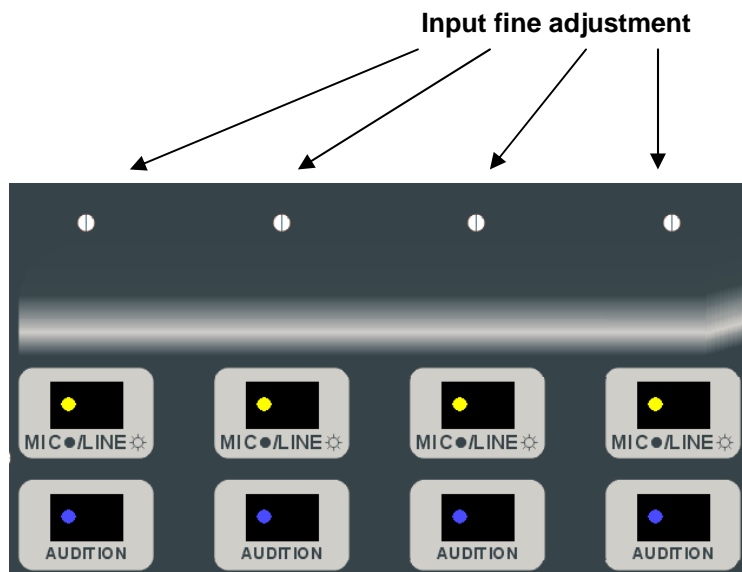

This is a setup fine adjustment and it's only necessary during the initial installation of the equipment.

The default factory setting is generally acceptable for most of the installations.



The controls associate to each one of the channels are the following:

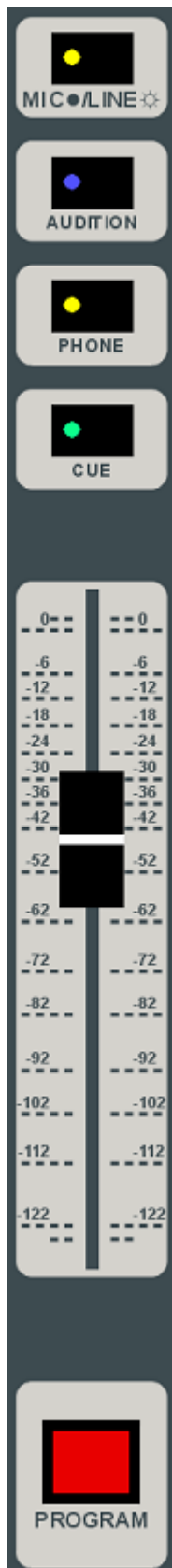

Input selection is accomplished through “**MIC/LINE**” switch. When “**LINE**” input is selected the switch yellow indicator will illuminate.

“**AUDITION**” push button: it sends the connected Mic or Line signal to AUDITION bus. Indicator will illuminate in blue color when it’s pressed.

“**PHONE**” push button: it sends the connected Mic or Line signal to PHONE bus. Indicator will illuminate in yellow color when it’s pressed.

“**CUE**” push button: it sends the connected Mic or Line signal to CUE bus. Indicator will illuminate in green color when it’s pressed.

With the sliding **FADER** you can adjust the output level of the Audio signal of the selected channel and sent to PROGRAM, AUDITION, PHONE and CUE buses (when respective sending buttons are pressed).

“**PROGRAM**” push button: it sends the connected Mic or Line signal to PROGRAM bus. Indicator will illuminate in red color when it’s pressed.

#### 4.2. Stereo double line channels.

The **AEQ BRAVO** mixer is equipped with eight independent stereo double Line inputs. Those are asymmetrical inputs at line level with RCA connectors:

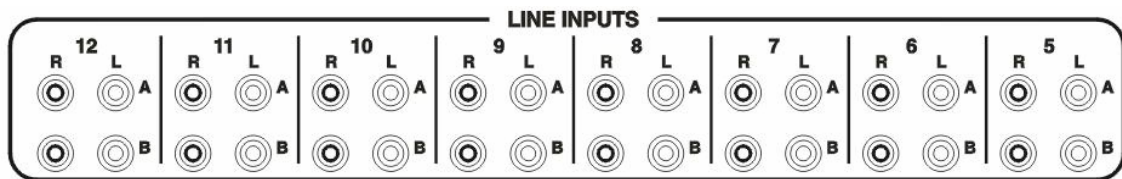

Each input has a double fine adjustment of input gain. An specific tool is needed in order to make this adjustment:

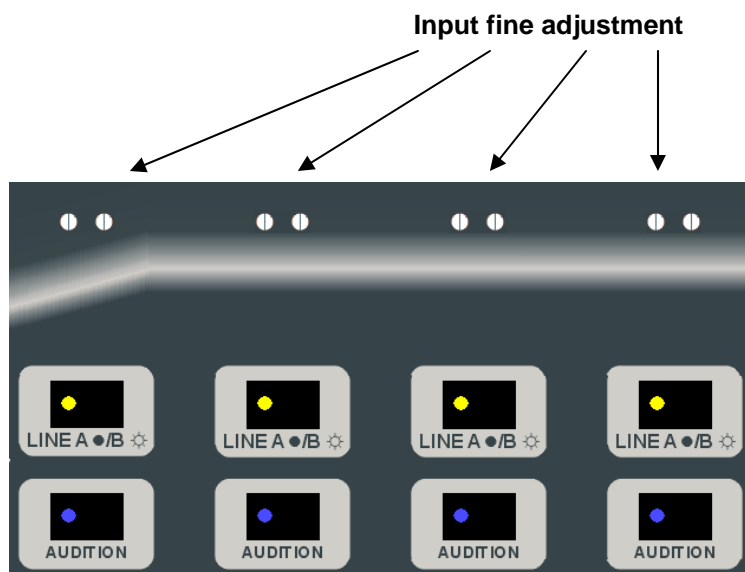

This is a setup fine adjustment and it's only necessary during the initial installation of the equipment.

The default factory setting is generally acceptable for most of the installations.

The controls of each stereo line channel are the following:

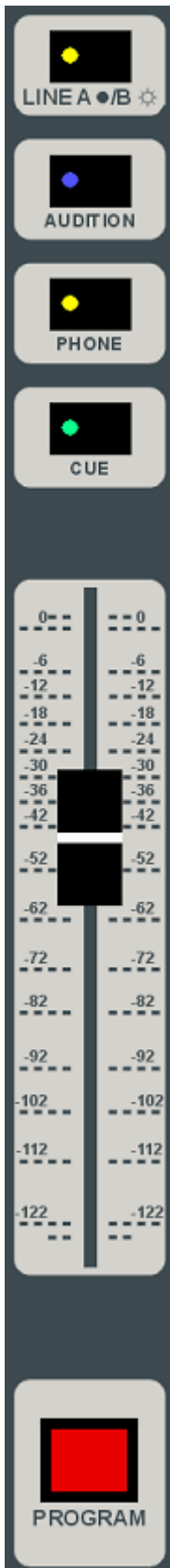

**Line A or Line B** selector. When “LINE B” input is selected the switch yellow indicator will illuminate.

“**AUDITION**” push button: it sends the selected Line signal to AUDITION bus. Indicator will illuminate in blue color when it’s pressed.

“**PHONE**” push button: it sends the selected Line signal to PHONE bus. Indicator will illuminate in yellow color when it’s pressed.

“**CUE**” push button: it sends the selected Line signal to CUE bus. Indicator will illuminate in green color when it’s pressed.

With the sliding **FADER** you can adjust the output level of the Audio signal coming from the selected channel and sent to PROGRAM, AUDITION, PHONE and CUE buses (when respective sending buttons are pressed).

“**PROGRAM**” push button: it sends the selected Line signal to PROGRAM bus. Indicator will illuminate in red color when it’s pressed.

### 4.3. Monitoring and control area.

Monitoring and control area allows you to access and control a series of functions that are described next.



### 4.3.1. PROGRAM output.

Adding function for the **main output** (“PGM OUTPUT”) is done in this area. This stereo output is available on the back panel through XLR connectors for L and R channels. These outputs are transformer balanced.

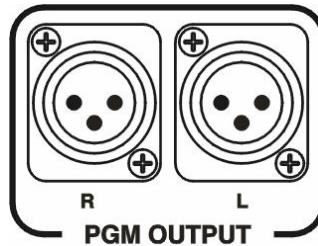

This output and the AUDITION one (see section 4.3.2) have a double adjustment of gain (for L and R channels). A specific tool is needed in order to make this adjustment. The default factory setting is generally acceptable for most of the installations.

**AUDITION output adjustment**

**PROGRAM output adjustment**



### 4.3.2. AUDITION output.

The **AEQ BRAVO** mixer has this stereo output available on the back panel through Hartmann type connectors for L and R channels. These outputs are transformer balanced. See adjustment on section 4.3.1.

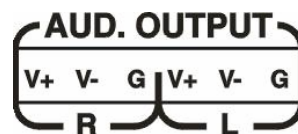

### 4.3.3. RECORDING outputs.

The **AEQ BRAVO** mixer has **3 recording outputs**, which parallels the main output (“PGM OUTPUT”). These stereo outputs are available on the back panel through RCA connectors for L and R channels. These are unbalanced (asymmetrical) signals.

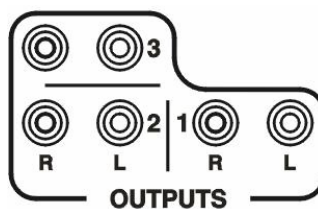

#### 4.3.4. Control room monitoring.



This area has independent stereo level control for monitors (“MON.”) and headphones (“HPHONE”).

The audio that will be sent to control monitors and headphones can be selected by using the push buttons. “PROGRAM”, “AUDITION” or “CUE” signal can be selected.

Stereo control monitors output (“CTRL MON.”) at line level is available on the back panel through Hartmann type connector. Stereo control headphones output (“HPHONE”) is available on monitoring and control area (down on the left) through ¼” stereo Jack connector.



This control room monitoring system also has an internal power amplifier that sends the selected signal to two speakers located on the front VU-meters panel through the following back panel connector:

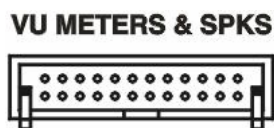

#### 4.3.5. Studio room monitoring.



This area has independent stereo level control for monitors (“MON.”) and headphones (“HPHONE”).

The audio that will be sent to studio monitors and headphones can be selected by using the push buttons. “PROGRAM”, “AUDITION” or “CUE” signal can be selected.

Stereo studio monitor output (amplified 10W + 10W) and stereo studio headphone output are available on the back panel through Hartmann type connectors.



#### 4.3.6. “AIR” or “EXTERNAL” input.

This input can be configured as “AIR” or “EXTERNAL” by means of an internal programming jumper (P.J.). See section 5.1.

The factory setting of this input is “AIR”. When the “AIR (EXT.)” send key is pressed, this signal is directed to CUE bus, so both control room and studio monitoring are possible. The most common use for this option is to use a radio tuner to monitor the transmitted signal.



If this input is internally configured as “EXTERNAL”, when the “AIR (EXT.)” send key is pressed it will be directed to the Program output. The most frequent use for this option is to insert time tones or station identification.

“AIR (EXT.)” input is stereo and the RCA connectors are located on the back panel.

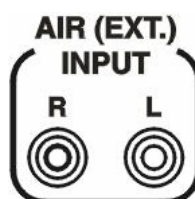

#### 4.3.7. Internal telephone hybrids or four-wire interfaces for external hybrids.

The **AEQ BRAVO** mixer has 1 double telephone channel with 2 internal telephone hybrids. It's configurable through internal programming jumpers (P.J.) to work with internal hybrids (this is the usual Factory setting) or with external hybrids. See section 5.1.

Both telephone hybrids receive audio signal from the different input modules through the "PHONE" switches of these modules (see sections 4.1 and 4.2). Both hybrids has the following independent controls:

 <p>TELEPHONE HYBRID 1</p> <p>C adj</p> <p>R adj</p> <p>OFF HOOK Ring</p> <p>SEND</p> <p>RETURN</p> <p>PROGRAM</p> <p>AUDITION</p> <p>CUE</p>	<p>Line's capacitive component adjustment.</p> <p>Line's resistive component adjustment.</p> <p>"OFF HOOK" switch.</p> <p>"RING" light indicator: it shows an incoming call.</p> <p>"SEND" potentiometer to control the sending level to the phone line.</p> <p>"RETURN" potentiometer to control the returning level from the phone line.</p> <p>The return signal from the phone line can be sent to "PROGRAM", "AUDITION" and/or "CUE" by using the push buttons.</p>
---	--

Internally, both modules have a buzzer for audible notification of calls. These buzzers are associated to the "RING" light indicators. Therefore, there are two switches on the back panel to activate (up) or deactivate (down) the sound of those buzzers.

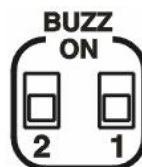



For optimum functioning of each one of the internal hybrids, you must **pre-adjust** them in order to achieve maximum adaptation to the local phone line. This pre-adjustment is described in section 4.3.7.1. In addition, you can use the “C adj” potentiometer to make hot adjustments to the phone line impedance: this small adjustments can be made if a certain lack of adaptation to the phone line is detected in the return audio.

Connections for the **internal hybrids** can be made by using the RJ-11 connectors on the back panel for the phone line (“LINE”) and for an auxiliary telephone (“SET”). It’s also possible to connect to the phone line by using the 2 pins Hartmann type connectors “TELPH. L1” y “TELPH. L2”.

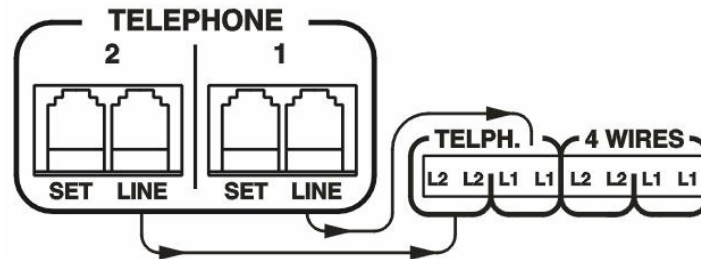

In case of using the **external hybrids** (4 wires interface) option, “4 WIRES L1” and “4 WIRES L2” connectors will be used for signal returning and “TELPH. L1” and “TELPH. L2” connectors will be used for signal sending.

#### 4.3.7.1. Adjusting the internal hybrids.

The two hybrids built into the **AEQ BRAVO** mixer are analog-type hybrids. This type of hybrids requires some previous adjustments for perfect hook-up to the phone line. There are two adjustment mechanisms for this purpose: one for the line’s resistive component, with adjustments taking place via the “**R adj**” Trimmer, and the other for the capacitive component, with adjustments by the “**C adj**” potentiometer.

To adjust the resistive component, proceed as follows:

Set up a phone call, making sure that there is no audio input on the other end of the line. A 1 KHz signal tone is sent, from one of the console’s inputs, to the line send output. The hybrid’s rejection level is adjusted by means of the “**R adj**” trimmer, while checking the level on LED VU-meters. When a minimal reading is registered on the VU-meter, the maximum rejection that the telephone hybrid is able to produce has been reached and the “**R adj**” trimmer adjustment is stopped.

The adjustment of the capacitive component is a fine-tuning of the hybrid’s behaviour. It is adjusted by means of “**C adj**” potentiometer when, for example, an incoming call’s signal is low or has poor quality.

#### 4.3.8. Talkback (“T’BACK”) circuit.

The **AEQ BRAVO** mixer includes an internal talkback microphone, with front-panel access. When the “**ST. HPHONE**” push button is pressed, you enable the circuit that sends talkback to the studio headphones. This button is only activated momentarily, so you have to keep it pressed during the entire time you are generating talkback. When you press the “**PHONE**” push button, you enable the circuit that sends talkback to the phone send. The same as in the previous case, this button is only activated while pressed.

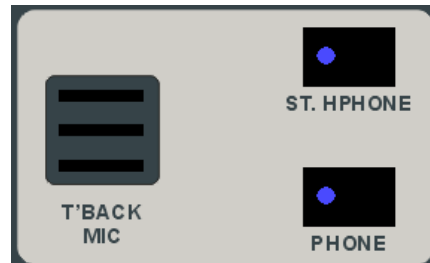

#### 4.3.9. Studio monitors muting.

This muting is done when a **Mic./Line** channel is activated through its “**PROGRAM**” push button (regardless of whether the selected input is micro or line and regardless of fader position). This muting of the monitors is necessary to avoid feedback.

This monitor muting function can be configured for each one of the four Mic./Line channels by means of internal programming jumpers (P.J.). See section 5.1.

#### 4.3.10. Studio signaling circuit.

This circuit provides 24V DC voltage for lighting the signal lamps. “**SIGNALING**” connector on the back panel houses three contacts (C1, C2 and C3) to manage these lamps. Also on the back panel, on the right of the Hartmann type connectors, there is a signaling fuse compartment (0.4 Amp. Slow Blow type).



The **red** “ON AIR” lamp must be connected to C1 and C2. The **green** lamp must be connected to C1 and C3. The signaling works in the same way as the monitor muting, i.e., it’s activated/deactivated by activating/deactivating a **Mic./Line** channel through its “**PROGRAM**” push button (regardless of whether the selected input is micro or line and regardless of fader position).

This signaling function can be activated or not by means of the same internal programming jumpers (P.J.) that are used for studio monitor muting configuration. See section 5.1.

#### 4.3.11. Remote control of external equipments.

The **AEQ BRAVO** mixer has four Hartmann type connectors (named “**REMOTE**”) for remote control of external equipments. These controls will only operate with the four first stereo double line channels and each one of them is activated/deactivated by activating/deactivating one of those channel through its “**PROGRAM**” push button (whether the selected line is A or B).

#### 4.4. VU-meters panel.

The **AEQ BRAVO** mixer has a panel with two stereo VU-meters, named “PROGRAM” and “SELECT”, and two speakers that receive the signal selected on the control room monitoring area. Those signals reach the panel through a flat cable (see section 4.3.3).

“**PROGRAM**” VU-meter shows the level of PROGRAM output and “**SELECT**” VU-meter shows the level of the signal selected on the control room monitoring area.

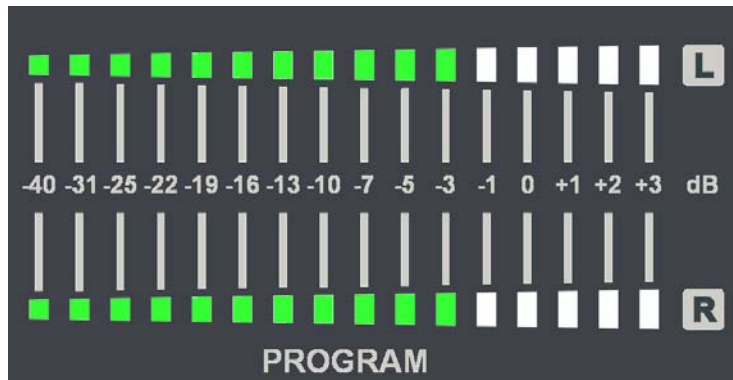

Regarding the speakers, you have the possibility of muting them by removing the “MUTE” connector that is located on the back panel:



## 5. INTERNAL PROGRAMMING AND CONNECTION DIAGRAMS.

### 5.1. Programming and internal adjustments.

The **AEQ BRAVO** mixer has a series of internal adjustments and programming jumpers (P.J.) that allows you to change some of the factory-set functions.

These adjustments and programming jumpers should only be accessed by staff qualified for this type of operations, as the adjustment mechanisms and P.J. are placed on the internal printed circuit boards.

#### Inputs board.

Function	P.J. J1	P.J. J2	P.J. J3	P.J. J4
Studio monitors muting and signaling functions activated for channel 1 (Mic./Line)	1-2 *			
The same for channel 2 (Mic./Line)		1-2 *		
The same for channel 3 (Mic./Line)			1-2 *	
The same for channel 4 (Mic./Line)				1-2 *

#### Control board.

Function	P.J. J1	P.J. J2
"AIR (EXT.)" input with send to CUE bus	1-2 *	1-2 *
"AIR (EXT.)" input with send to PROGRAM bus	2-3	2-3

Function	P.J. J3	P.J. J4	P.J. J5	P.J. J7
Console using Internal Hybrid 1	2-3 *	2-3 *	1-2 *	1-2 *
Console using External Hybrid 1 (4 wires mode)	1-2	1-2	2-3	2-3

Function	P.J. J8	P.J. J9	P.J. J10	P.J. J12
Console using Internal Hybrid 2	2-3 *	2-3 *	1-2 *	1-2 *
Console using External Hybrid 2 (4 wires mode)	1-2	1-2	2-3	2-3

#### \* Factory Setting

The **settings** can be changed internally, on the **control board**, as follows:

- Adjustment of the left "AIR (EXT.)" input sensitivity: can be done using VR1.
- Adjustment of the right "AIR (EXT.)" input sensitivity: can be done using VR2.
- Adjustment of the left RECORDING outputs: can be done using VR3.
- Adjustment of the right RECORDING outputs: can be done using VR4.
- Adjustment of the TALKBACK microphone sensitivity: can be done using VR5.

## 5.2. Audio connection.

The following diagram shows an example of typical connection for radio broadcast studios:

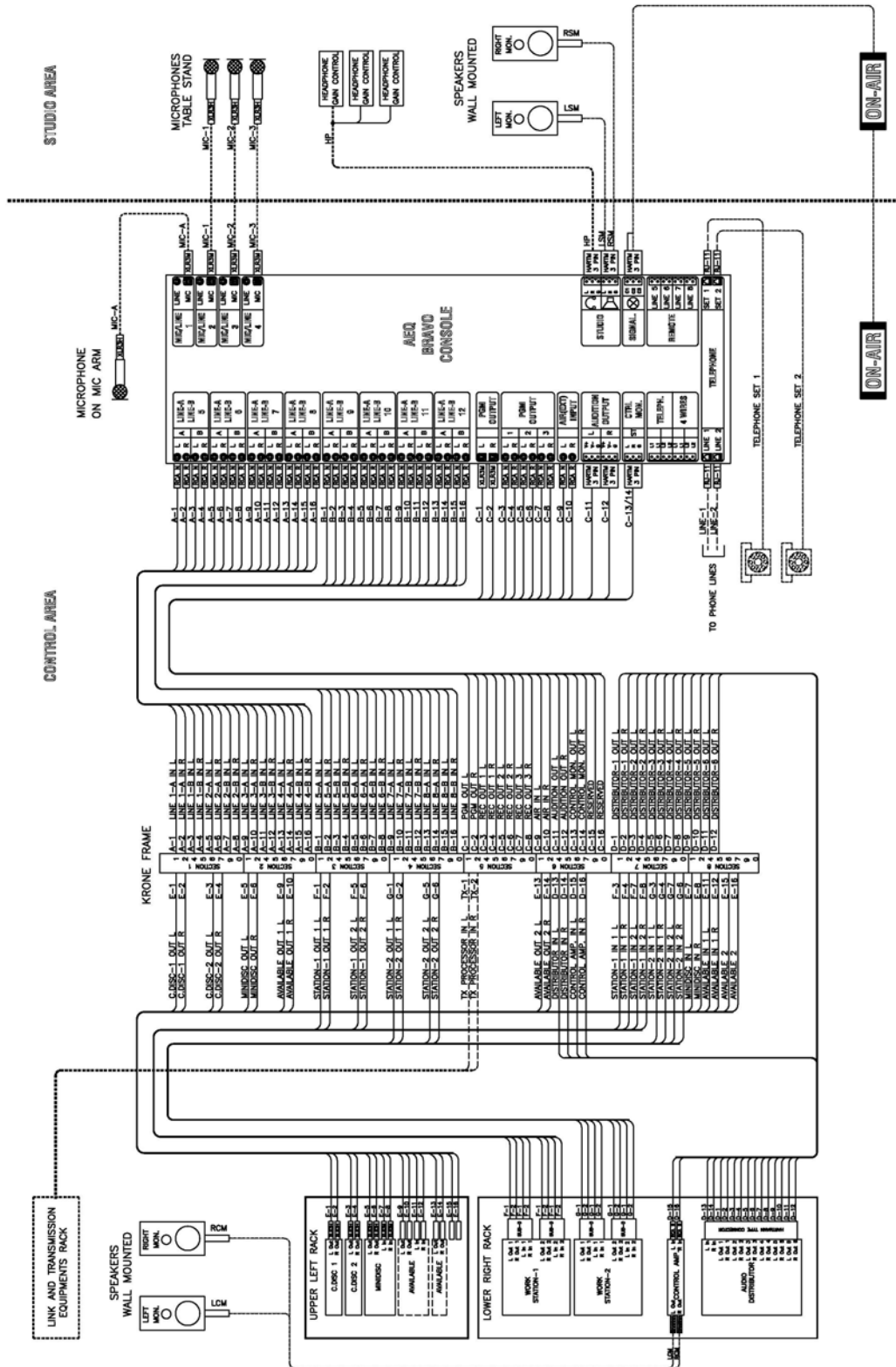

**5.3. External hybrids connection.**

**Connection diagram for External Hybrid**

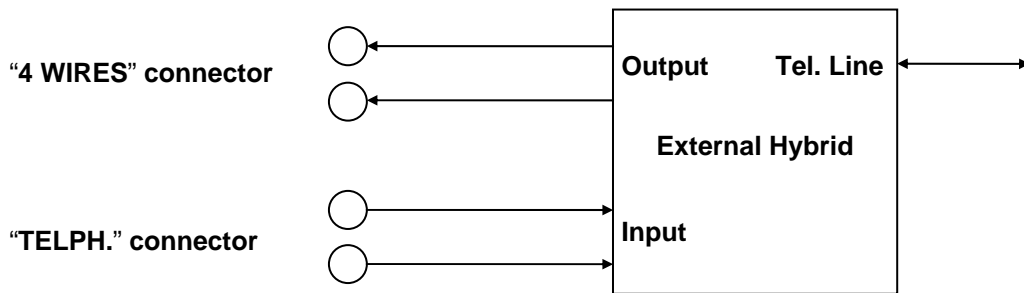

See section 4.3.7.

**5.4. Signaling connection.**

**Connection diagram for signaling**

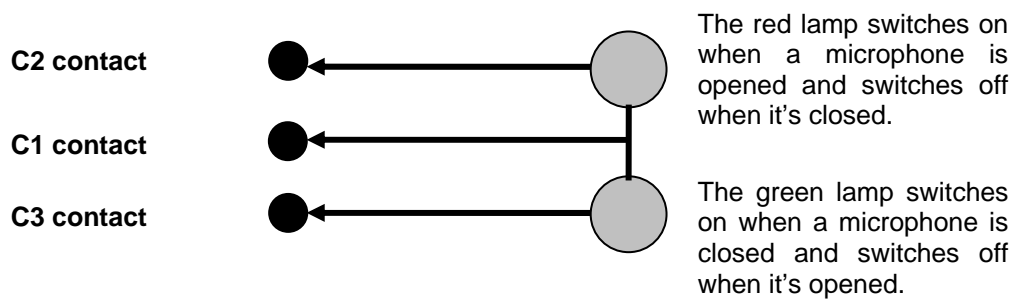

See section 4.3.10.

## 6. TECHNICAL SPECIFICATIONS.

### 6.1. Mono Mic./Line inputs.

Electronically balanced Mic. input.  
Asymmetrical Line input.  
Connector Mic.: Female XLR.  
Connector Line: Female RCA.  
Impedance: Micro: > 2 KOhm.  
Line: > 20 KOhm.  
Input range: Mic: -71dBu / -17dBu.  
Line: -34dBu / +22dBu.  
Program nominal level: 0dBu.  
Equivalent noise: -117dBu 20Hz/20KHz.  
Fader adjustment: 122 dB.

### 6.2. Stereo Line inputs.

Asymmetrical input.  
Connector: Female RCA.  
Input impedance: > 20 KOhm.  
Input range: -20 dBu / +22 dBu.  
Fader adjustment: 122 dB.

### 6.3. Program output.

Transformer balanced.  
Connector: Male XLR.  
Output impedance: < 50 Ohm.  
Nominal output level: 0 dBu.  
Maximum output level: +14 dBu THD<0,2% 30Hz/20KHz  
+21 dBu THD<0,2% 60Hz/20KHz  
Frequency bandwidth: +/-1,2 dB 20Hz/20 KHz.  
Absolute noise: -78 dBu 20Hz/20 KHz (no input channel routed to Program).

### 6.4. Recording outputs.

Asymmetrical.  
Connector: Female RCA.  
Output impedance: 1 KOhm.  
Nominal output level: 0dBu.

### 6.5. Signaling.

Connector: "Hartman" type.  
Output voltage: 24 V.  
Maximum admissible load: 6 VA.  
Signaling fuse: 0.4A (Slow Blow type).

### 6.6. Power supply.

Input voltage: 100/240 V AC, 50-60 Hz.  
Maximum consumption: 100 VA.  
Power supply fuse: 1.6A (Slow Blow type).

## 6.7. Dimensions and weight.

### 6.7.1. Dimensions.

#### Placed on a table.

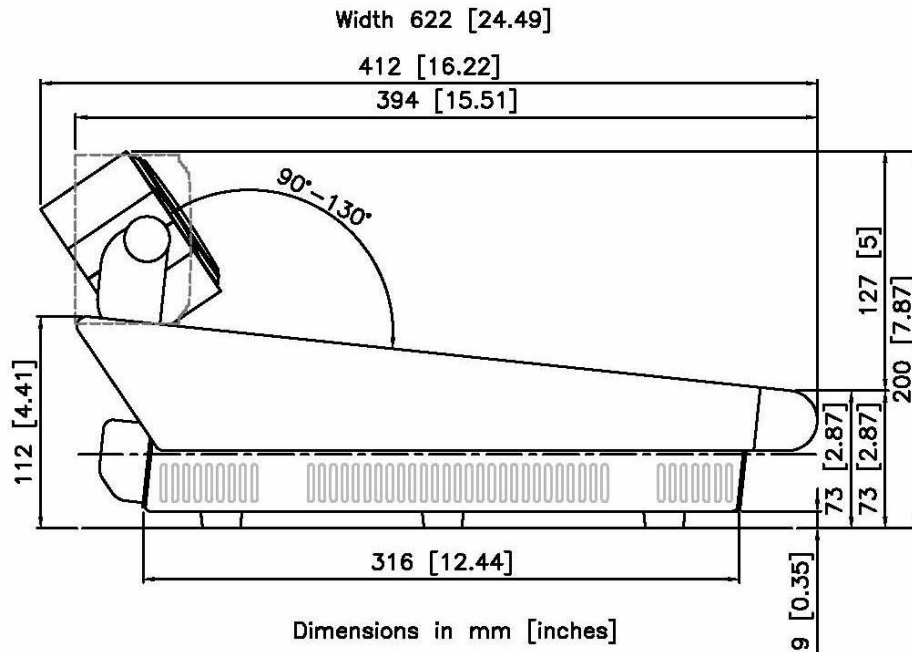

Cut-out for built-in: 580mm x 400mm [22,83 x 15,75 inches]

#### Sunk into custom woodwork.

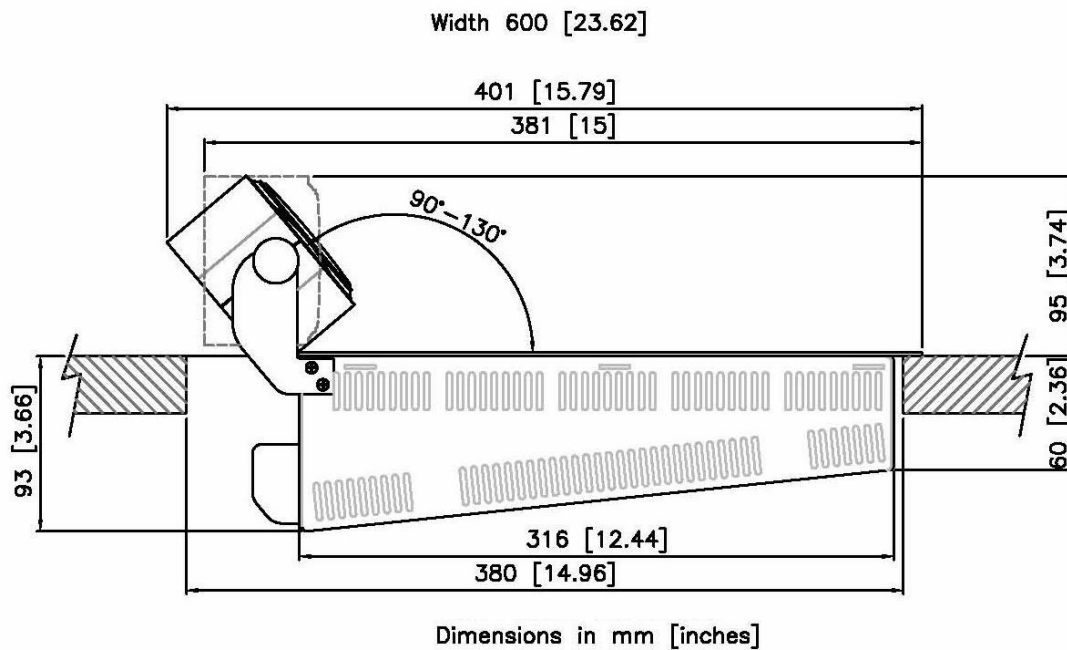

Cut-out for built-in: 580mm x 380mm [22,83 x 14,96 inches]

### 6.7.2. Weight.

Approximately 10 Kilograms (22 pounds).